



SPIDER CONNECTOR

CONSTRUCTION WITHOUT BEAM
SUPPORT - SLAB - SUPPORT

CONCEPT AND EXPERIMENTAL INVESTIGATIONS

INTRODUCTION

With the SPIDER Connector punctual supported CLT flat slabs with a span length of more than 5 m can be realized without any binding beams. The system generally has two functions: reinforcement in the area of the support and suspension of the CLT flat slab by means of radial arms and fully threaded screws. Furthermore it transmits the vertical load of the support from the top of the building to the ground floor without stressing the CLT perpendicular to the grain. Hereafter the system and the laboratory tests of the University of Innsbruck are presented.

SPIDER CONNECTOR - COMPONENTS

The SPIDER Connector is composed by the following main elements:

- TOP PLATE: receiving the vertical load from the upper support;
- HEART OF STEEL AND CANTILEVER: suspension and reinforcement of the CLT flat slab;
- LOAD CONDUCTION: load transmission of above supports and adjoining floor load;
- BASE PLATE: load transmission to next support.

The entire system can be mounted easily from the top and is loadable immediately.

It is possible to integrate the SPIDER Connector in the floor structure because of its low construction height and it is thus protected from the exposure of fire from the upper floor. By the use of the connector the lower wooden surface of the cross laminated timber ceiling can remain visible. Furthermore all steel parts are also encapsulated in case of fire from the bottom floor by the CLT slab and the timber support.

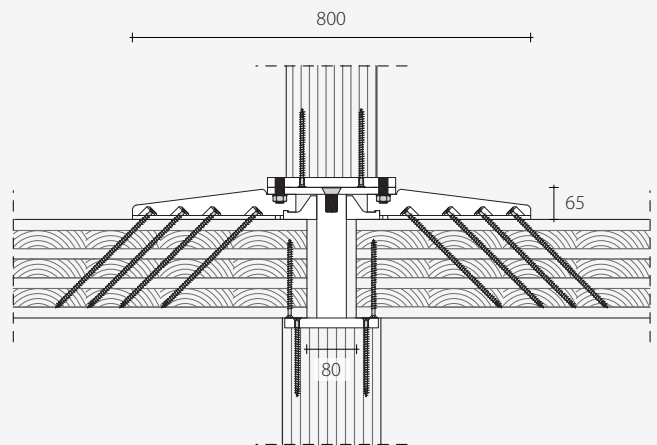
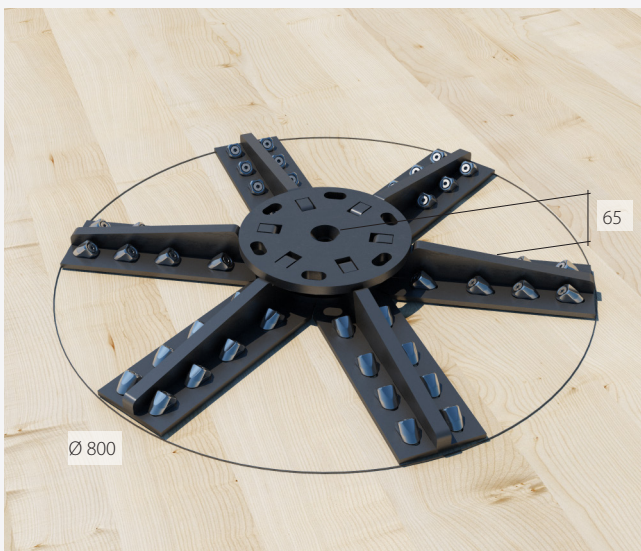

Figure 1: main dimensions of the SPIDER connector

COMPARISON OF SYSTEMS: WITHOUT REINFORCEMENT - CLT REINFORCED BY FULLY THREADED SCREWS (VGS) - SPIDER CONNECTOR

Figures 2 and 3 compare the performance of the SPIDER Connector System with already existing design variants:

1. Unreinforced: load transfer purely through the load capacity of the CLT panel perpendicular to the grain;
2. Reinforced perpendicular to the grain: maximum number of fully threaded screws on the cross section;
3. SPIDER Connector: combination of support, suspension, reinforcement and load transmission.

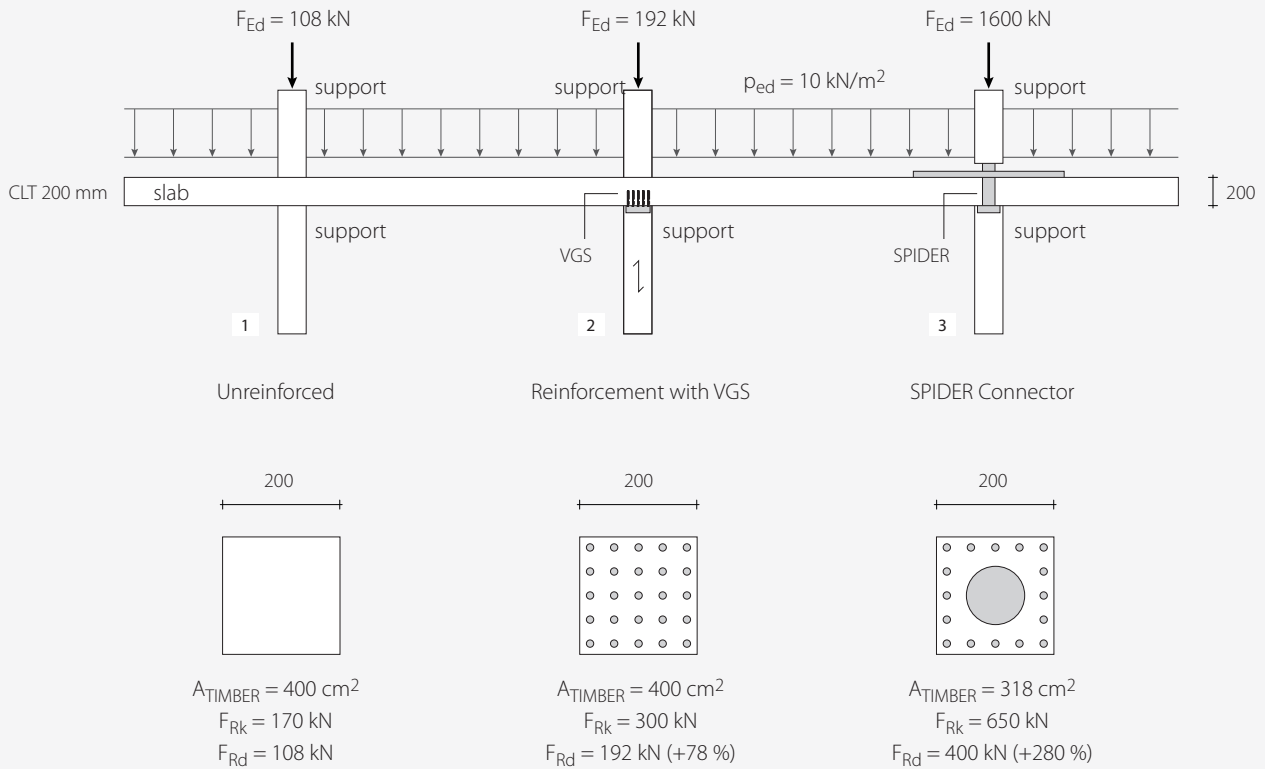

Figure 2: comparison of the performance for different versions (schematic drawing)

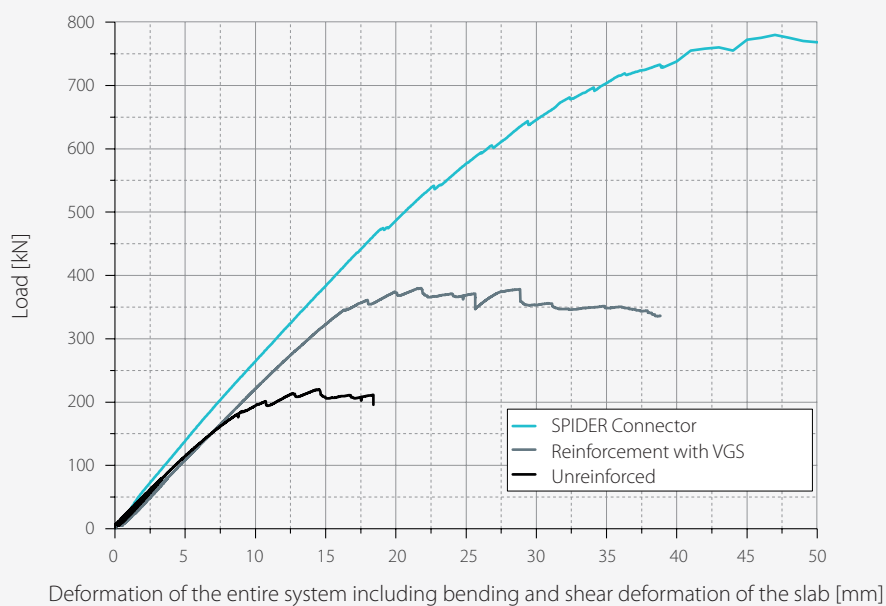

Figure 3: comparison of the performance for different versions, load-displacement curve

ASSEMBLY OF THE SPIDER CONNECTOR SYSTEM

The simple on-site assembly of a point supported CLT flat slab with the SPIDER Connector System is carried out in the following steps:

- positioning the supports with the pre-assembled SPIDER components base plate and load conduction;
- installation of the CLT elements above the rows of supports;
- lifting the CLT elements between the rows of supports (possibly scaffolding or shiplap);
- mounting and screwing SPIDER Connector from the top floor;
- bending and shear stiff connection between the CLT panels;
- installing the top supports for the next floor directly on the top plate of the SPIDER Connector.

Figure 4: assembling the SPIDER Connector system

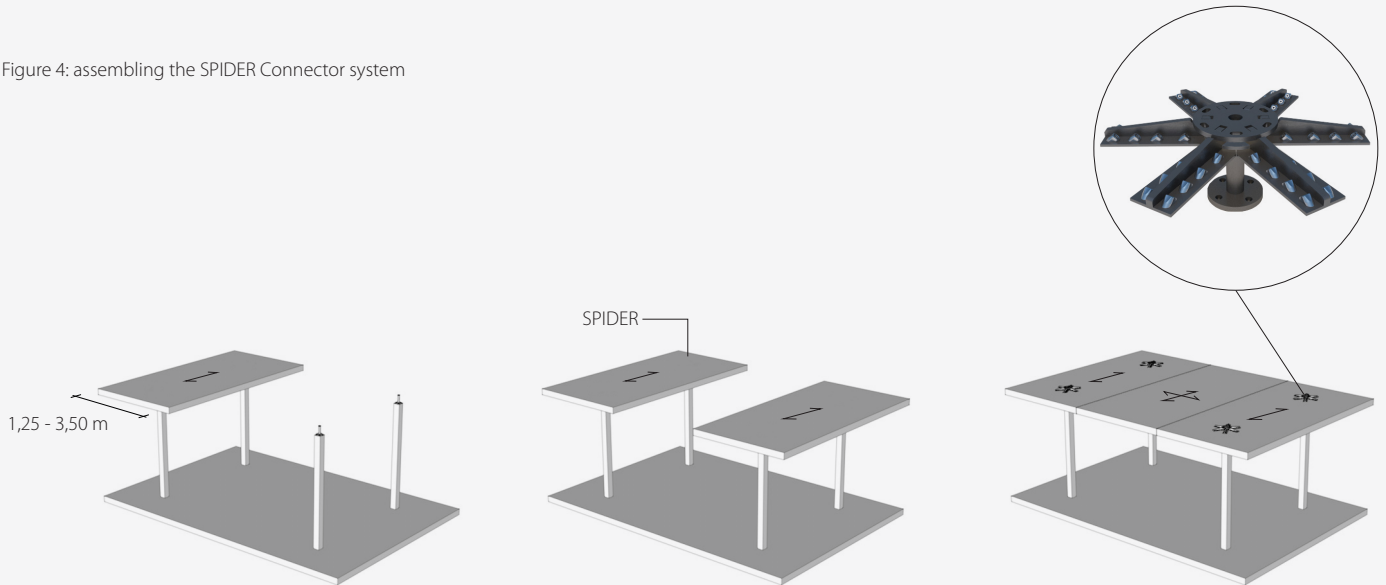

CONSTRUCTION WITHOUT BEAM

The SPIDER Connector System makes it possible to build point supported flat slabs of cross laminated timber with service loads of 10 kN/m^2 and spans of 5 to 7 m.

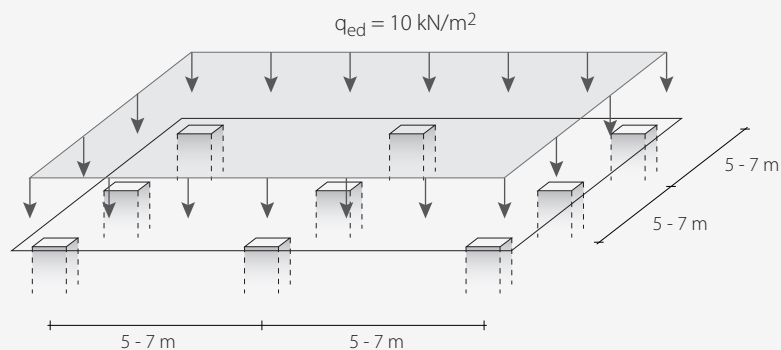

EUROPEAN TECHNICAL ASSESSMENT (ETA)

A European Technical Assessment with the OIB in Vienna is planned for the SPIDER Connector for 2018.