

FULLY THREADED SCREW WITH COUNTERSUNK OR HEXAGONAL HEAD

3 THORNS TIP

Thanks to the 3 THORNS tip, minimum installation distances are reduced. More screws can be used in less space and larger screws in smaller elements. Costs and time for project implementation are reduced.

CERTIFICATION FOR TIMBER AND CONCRETE

Structural connector approved for timber applications according to ICC ELC-4645 listing report in Canada and for timber-concrete applications according to ETA-22/0806.

TENSILE STRENGTH

Deep thread and high strength steel for excellent tensile or sliding performance. Approved for structural applications subject to stresses in any direction vs the grain (0° ÷ 90°). Can be used on steel plates in combination with the VGU or HUS washers.

COUNTERSUNK OR HEXAGONAL HEAD

Countersunk head up to L = 600 mm, ideal for use on plates or for concealed reinforcements. Hexagonal head L > 600 mm to facilitate gripping with screwdriver.

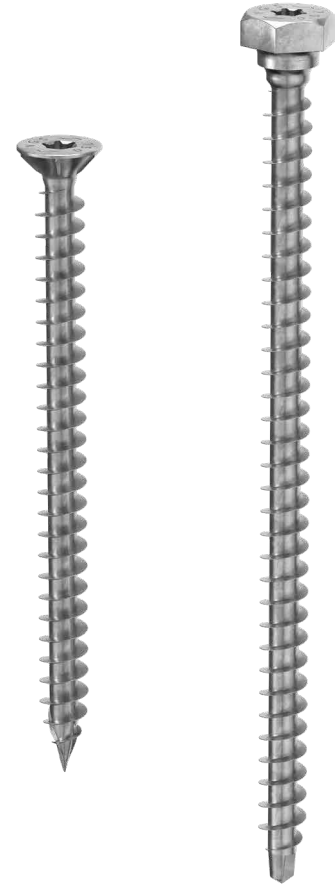

MANUALS



BIT INCLUDED

DIAMETER [mm]	9 9	13 13
LENGTH [mm]	80 80	1500 1500
SERVICE CONDITION	EC1 DRY	
ATMOSPHERIC CORROSIVITY	C1 C2	
WOOD CORROSIVITY	T1 T2	
MATERIAL	Zn ELECTRO PLATED	electrogalvanized carbon steel
CORE HARDNESS	<390 HV	as required in CSA 086:24 ⁽¹⁾



CANADIAN DESIGN VALUES

USA, EU and more design values available online.

METAL-to-TIMBER recommended use:

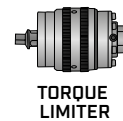

FIELDS OF USE

- timber based panels
- solid timber
- glulam (Glued Laminated Timber)
- CLT and LVL
- high density woods

⁽¹⁾ Core hardness < 390 HV guaranteed for structural timber screws diameter 6 mm and above.



TC FUSION

The ETA-22/0806 approval of the TC FUSION system allows the VGS screws to be used together with the reinforcements in the concrete so that the panel floor slabs and the bracing core can be bonded together with a small integration of the casting.

GEOMETRY AND MECHANICAL CHARACTERISTICS

VGS Ø9

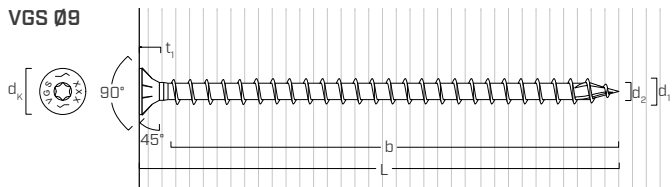

$L \leq 520$ mm

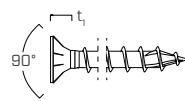

$L > 520$ mm

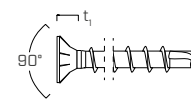

VGS Ø11

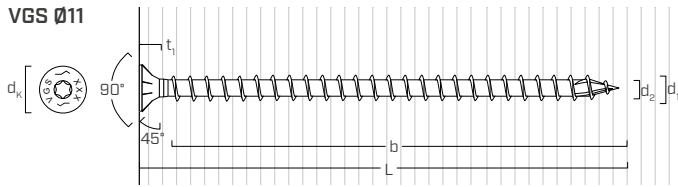

$L \leq 250$ mm

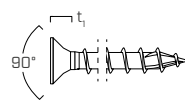

$250 \text{ mm} < L \leq 600$ mm

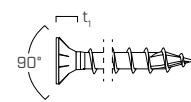

$L > 600$ mm

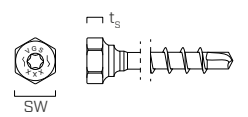

VGS Ø13

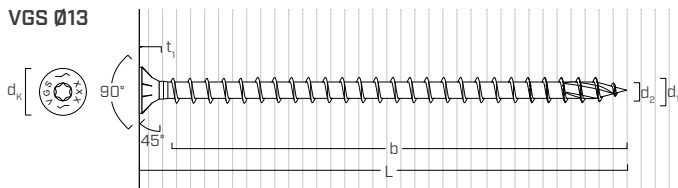

$L \leq 250$ mm

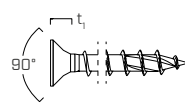

$250 \text{ mm} < L \leq 600$ mm

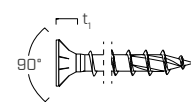

$L > 600$ mm

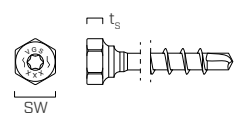

GEOMETRY

Nominal diameter	d_1	[mm]	9	11	11	13	13
Length	L	[mm]	-	≤ 600 mm	> 600 mm	≤ 600 mm	> 600 mm
Countersunk head diameter	d_K	[mm]	16,00	19,30	-	22,00	-
Countersunk head thickness	t_1	[mm]	6,50	8,20	-	9,40	-
Wrench size	SW	-	-	-	SW 17	-	SW 19
Hexagonal head thickness	t_s	[mm]	-	-	6,40	-	7,50
Root diameter	d_2	[mm]	5,90	6,60	6,60	8,00	8,00
Pre-drilling hole diameter ⁽¹⁾	$d_{V,S}$	[mm]	5,0	6,0	6,0	8,0	8,0
Pre-drilling hole diameter ⁽²⁾	$d_{V,H}$	[mm]	6,0	7,0	7,0	9,0	9,0

(1) Pre-drilling valid for softwood.

(2) Pre-drilling valid for hardwood and beech LVL.

MECHANICAL PARAMETERS

Nominal diameter	d_1	[mm]	9	11	13	
Factored tensile strength	Φ_{f_u}	[kN]	17,84	23,17	31,96	
Bending yield strength	F_{yb}	[MPa]	1069	1026	960	
Factored shear strength of the screw	Φ_{v_s}	[kN]	10,50	13,14	19,30	
Specified withdrawal resistance per millimeter of threaded shank (tip included)	Y_w	[N/mm]	G=0.35	78,56	96,02	113,5
			G=0.42	90,9	111,1	131,3
			G=0.49	102,8	125,7	148,5
			G=0.55	112,8	137,9	162,9

CODES AND DIMENSIONS

d ₁ [mm]	CODE	L [mm]	b [mm]	pcs
9 TX40	VGS9100	100	90	50
	VGS9120	120	110	50
	VGS9140	140	130	50
	VGS9160	160	150	50
	VGS9180	180	170	50
	VGS9200	200	190	50
	VGS9220	220	210	50
	VGS9240	240	230	50
	VGS9260	260	250	50
	VGS9280	280	270	50
	VGS9300	300	290	50
	VGS9320	320	310	50
	VGS9340	340	330	50
	VGS9360	360	350	50
	VGS9380	380	370	50
	VGS9400	400	390	50
	VGS9440	440	430	25
	VGS9480	480	470	25
	VGS9520	520	510	25
	VGS9560	560	550	25
VGS9600	600	590	25	
11 TX 50	VGS1180	80	70	25
	VGS11100	100	90	25
	VGS11125	125	115	25
	VGS11150	150	140	25
	VGS11175	175	165	25
	VGS11200	200	190	25
	VGS11225	225	215	25
	VGS11250	250	240	25
	VGS11275	275	265	25
	VGS11300	300	290	25
	VGS11325	325	315	25
	VGS11350	350	340	25
	VGS11375	375	365	25
	VGS11400	400	390	25
	VGS11425	425	415	25
	VGS11450	450	440	25
VGS11475	475	465	25	
VGS11500	500	490	25	
VGS11525	525	515	25	
VGS11550	550	540	25	
VGS11575	575	565	25	
VGS11600	600	590	25	
VGS11650	650	630	25	
VGS11700	700	680	25	
VGS11750	750	730	25	
VGS11800	800	780	25	
VGS11850	850	830	25	
VGS11900	900	880	25	
VGS11950	950	930	25	
VGS111000	1000	980	25	

d ₁ [mm]	CODE	L [mm]	b [mm]	pcs
13 TX 50	VGS1380	80	70	25
	VGS13100	100	90	25
	VGS13150	150	140	25
	VGS13200	200	190	25
	VGS13250	250	240	25
	VGS13300	300	280	25
	VGS13350	350	330	25
	VGS13400	400	380	25
	VGS13450	450	430	25
	VGS13500	500	480	25
VGS13550	550	530	25	
VGS13600	600	580	25	
VGS13650	650	630	25	
VGS13700	700	680	25	
VGS13750	750	730	25	
VGS13800	800	780	25	
VGS13850	850	830	25	
VGS13900	900	880	25	
VGS13950	950	930	25	
VGS131000	1000	980	25	
VGS131100	1100	1080	25	
VGS131200	1200	1180	25	
VGS131300	1300	1280	25	
VGS131400	1400	1380	25	
VGS131500	1500	1480	25	

RELATED PRODUCTS



HUS
TURNED WASHER



VGU
45° WASHER FOR VGS



TORQUE LIMITER
TORQUE LIMITER



WASP
HOOK FOR TIMBER ELEMENTS
TRANSPORT

EFFECTIVE THREAD USED IN CALCULATION

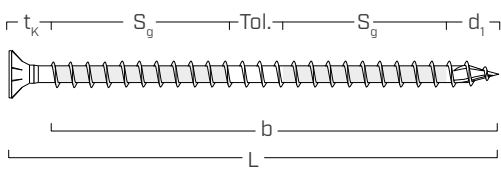

$$b = S_{g,tot} = L - t_k$$

represents the entire length of the threaded part (see table above)

$$S_g = (b - d_1 - Tol.) / 2$$

represents the partial length of the threaded part net of a laying tolerance (Tol.) of 10 mm

$t_k = 10$ mm or 20mm depending on head type and diameter

NOTES

- The length of the tip is equal to the nominal diameter of the respective fasteners, d_1 , as specified in the ELC-4645 report.

MINIMUM DISTANCES FOR AXIAL STRESSES | TIMBER

☺ screws inserted **WITH and WITHOUT pre-drilled hole**

d_1		9 [mm]	0.36 [in]	11 [mm]	0.44 [in]	13 [mm]	0.52 [in]
S_p	$7 \cdot d^{\dagger}$	63	2 1/2	77	3 1/16	91	3 9/16
S_Q	$5 \cdot d$	45	1 3/4	55	2 3/16	65	2 9/16
a_L	$10 \cdot d^{\dagger}$	90	3 1/2	110	4 3/8	130	5 1/8
e_Q	$4 \cdot d$	36	1 7/16	44	1 3/4	52	2 1/16

† For Douglas Fir–Larch and Western Red Cedar, this minimum spacing shall be increased by 50%.

SCREWS UNDER TENSION INSERTED WITH AN ANGLE α WITH RESPECT TO THE GRAIN

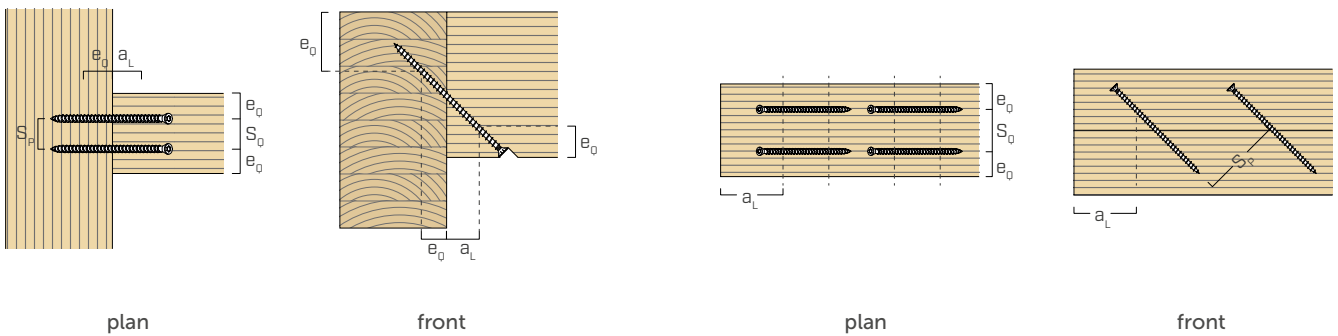

SCREWS INSERTED WITH $\alpha = 90^\circ$ ANGLE WITH RESPECT TO THE GRAIN

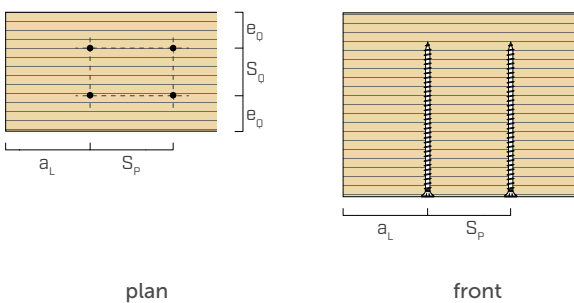

CROSSED SCREWS INSERTED WITH AN ANGLE α WITH RESPECT TO THE GRAIN

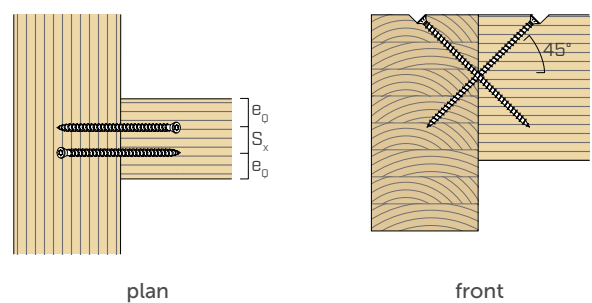

MINIMUM DISTANCES FOR SHEAR LOADS

 screws inserted **WITHOUT** pre-drilled hole $G \leq 0.44$

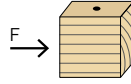

d_1		9 [mm]	0.36 [in]	11 [mm]	0.44 [in]	13 [mm]	0.52 [in]
S_p	12·d[‡]	108	4 1/4	132	5 3/16	156	6 1/8
S_Q	5·d	45	1 3/4	55	2 3/16	65	2 9/16
a_L	15·d[‡]	135	5 5/16	165	6 1/2	195	7 11/16
a	10·d[‡]	90	3 1/2	110	4 3/8	130	5 1/8
e_Q	10·d	90	3 1/2	110	4 3/8	130	5 1/8
e_p	5·d	45	1 3/4	55	2 3/16	65	2 9/16
S_x	2·d	18	11/16	22	7/8	26	1 1/32

[‡] For Western Red Cedar, this minimum spacing shall be increased by 50%.

 screws inserted **WITHOUT** pre-drilled hole $0.44 < G \leq 0.50$

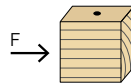

d_1		9 [mm]	0.36 [in]	11 [mm]	0.44 [in]	13 [mm]	0.52 [in]
S_p	18·d	162	6 3/8	198	7 13/16	234	9 1/4
S_Q	7·d	63	2 1/2	77	3 1/16	91	3 9/16
a_L	22·d	198	7 13/16	242	9 1/2	286	11 1/4
a	15·d	135	5 5/16	165	6 1/2	195	7 11/16
e_Q	12·d	108	4 1/4	132	5 3/16	156	6 1/8
e_p	7·d	63	2 1/2	77	3 1/16	91	3 9/16
S_x	3·d	27	1 1/16	33	1 5/16	39	1 9/16

 screws inserted **WITH** pre-drilled hole

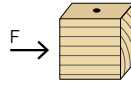

d_1		9 [mm]	0.36 [in]	11 [mm]	0.44 [in]	13 [mm]	0.52 [in]
S_p	5·d[†]	45	1 3/4	55	2 3/16	65	2 9/16
S_Q	4·d	36	1 7/16	44	1 3/4	52	2 1/16
a_L	12·d[†]	108	4 1/4	132	5 3/16	156	6 1/8
a	7·d[†]	63	2 1/2	77	3 1/16	91	3 9/16
e_Q	7·d	63	2 1/2	77	3 1/16	91	3 9/16
e_p	3·d	27	1 1/16	33	1 5/16	39	1 9/16
S_x	1,5·d	13,5	9/16	16,5	5/8	19,5	3/4

[†] For Douglas Fir–Larch and Western Red Cedar, this minimum spacing shall be increased by 50%.

α = load-to-grain angle

$d = d_1$ = nominal diameter of the screw

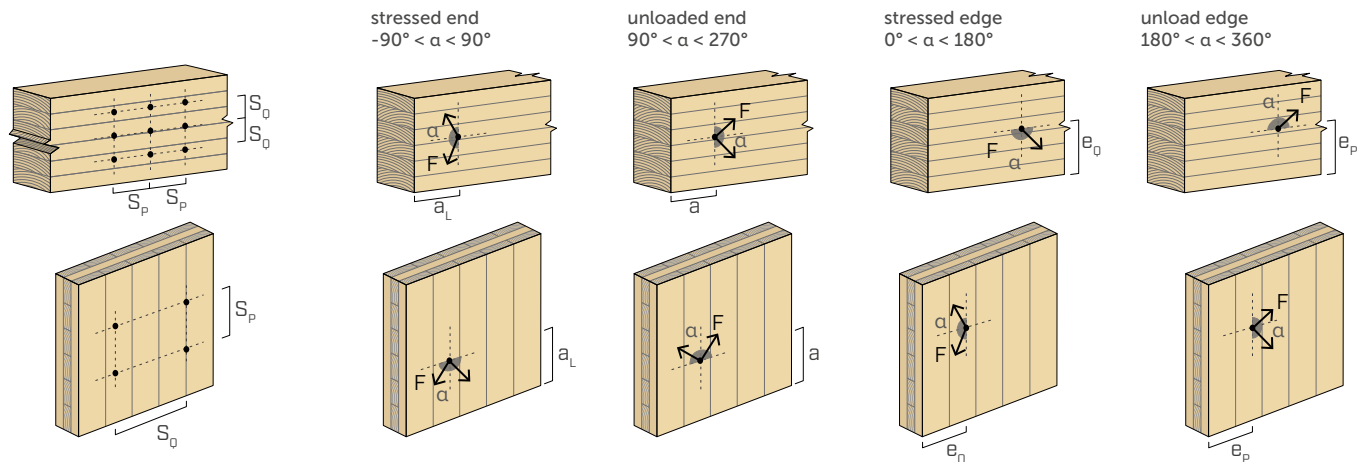

NOTES

- The minimum spacing and distances comply with Clause 12.12.5 of CSA-O86 2024, where d_1 refers to the nominal diameter of the self-tapping screw.
- The spacing, end, and edge distances for Rothoblaas screws installed in the narrow face of CLT panels shall comply with the specifications outlined in ETA-11/0030.
- The placement of fasteners subjected to axial loading shall be determined in accordance with Clause 12.12.5 of CSA-O86:2024.

geometry					TENSION/COMPRESSION ⁽¹⁾											
					$\alpha = 90^\circ$				total thread withdrawal $\alpha = 45^\circ$				end grain $\alpha = 0^\circ$			
					factored withdrawal resistance P_{rw}				factored withdrawal resistance P_{rw}				factored withdrawal resistance P_{rw} ⁽²⁾			
					G				G				G			
d_1	L	$S_{g,tot}$	A_{min}		0.35	0.42	0.49	0.55	0.35	0.42	0.49	0.55	0.35	0.42	0.49	0.55
[mm] [in]	[mm] [in]	[mm]	[mm]		[kN]	[kN]	[kN]	[kN]	[kN]	[kN]	[kN]	[kN]	[kN]	[kN]	[kN]	[kN]
9 0.36	100	4	81	110	4,45	5,15	5,83	6,40	4,05	4,69	5,30	5,81	2,23	2,58	2,91	3,20
	120	4 3/4	101	130	5,55	6,43	7,27	7,97	5,05	5,84	6,61	7,25	2,78	3,21	3,63	3,99
	140	5 1/2	121	150	6,65	7,70	8,71	9,55	6,05	7,00	7,92	8,69	3,33	3,85	4,35	4,78
	160	6 1/4	141	170	7,75	8,97	10,15	11,13	7,05	8,16	9,22	10,12	3,88	4,49	5,07	5,57
	180	7 1/8	161	190	8,85	10,24	11,59	12,71	8,05	9,31	10,53	11,56	4,43	5,12	5,79	6,36
	200	8	181	210	9,95	11,52	13,02	14,29	9,05	10,47	11,84	12,99	4,98	5,76	6,51	7,15
	220	8 5/8	201	230	11,05	12,79	14,46	15,87	10,05	11,63	13,15	14,43	5,53	6,39	7,23	7,94
	240	9 1/2	221	250	12,15	14,06	15,90	17,45	11,05	12,78	14,46	15,86	6,08	7,03	7,95	8,73
	260	10 1/4	241	270	13,25	15,33	17,34	19,03	12,05	13,94	15,77	17,30	6,63	7,67	8,67	9,51
	280	11	261	290	14,35	16,61	18,78	20,61	13,05	15,10	17,07	18,74	7,18	8,30	9,39	10,30
	300	11 3/4	281	310	15,45	17,88	20,22	22,19	14,05	16,25	18,38	20,17	7,73	8,94	10,11	11,09
	320	12 5/8	301	330	16,55	19,15	21,66	23,77	15,05	17,41	19,69	21,61	8,28	9,58	10,83	11,88
	340	13 3/8	321	350	17,65	20,43	23,10	25,35	16,05	18,57	21,00	23,04	8,83	10,21	11,55	12,67
	360	14 1/4	341	370	18,75	21,70	24,54	26,93	17,05	19,73	22,31	24,48	9,38	10,85	12,27	13,46
	380	15	361	390	19,85	22,97	25,98	28,50	18,05	20,88	23,62	25,91	9,93	11,49	12,99	14,25
	400	15 3/4	381	410	20,95	24,24	27,42	30,08	19,05	22,04	24,92	27,35	10,48	12,12	13,71	15,04
	440	17 1/4	421	450	23,15	26,79	30,30	33,24	21,05	24,35	27,54	30,22	11,58	13,39	15,15	16,62
	480	19	461	490	25,35	29,33	33,17	36,40	23,05	26,67	30,16	33,09	12,68	14,67	16,59	18,20
520	20 1/2	501	530	27,55	31,88	36,05	39,56	25,05	28,98	32,77	35,96	13,78	15,94	18,03	19,78	
560	22	541	570	29,75	34,42	38,93	42,72	27,05	31,29	35,39	38,83	14,88	17,21	19,47	21,36	
600	23 5/8	581	610	31,95	36,97	41,81	45,88	29,05	33,61	38,01	41,71	15,98	18,48	20,90	22,94	
11 0.44	80	3 1/8	59	90	3,97	4,59	5,19	5,70	3,61	4,17	4,72	5,18	1,98	2,29	2,60	2,85
	100	4	79	110	5,31	6,14	6,95	7,63	4,83	5,59	6,32	6,93	2,65	3,07	3,48	3,81
	125	4 15/16	104	135	6,99	8,09	9,15	10,04	6,35	7,35	8,32	9,13	3,50	4,04	4,58	5,02
	150	6	129	160	8,67	10,03	11,35	12,45	7,88	9,12	10,32	11,32	4,34	5,02	5,68	6,23
	175	6 7/8	154	185	10,35	11,98	13,55	14,87	9,41	10,89	12,32	13,51	5,18	5,99	6,78	7,43
	200	8	179	210	12,03	13,92	15,75	17,28	10,94	12,66	14,32	15,71	6,02	6,96	7,88	8,64
	225	8 7/8	204	235	13,71	15,87	17,95	19,69	12,47	14,42	16,32	17,90	6,86	7,93	8,97	9,85
	250	10	229	260	15,39	17,81	20,15	22,11	13,99	16,19	18,32	20,10	7,70	8,90	10,07	11,05
	275	10 7/8	254	285	17,07	19,75	22,35	24,52	15,52	17,96	20,32	22,29	8,54	9,88	11,17	12,26
	300	11 3/4	279	310	18,75	21,70	24,55	26,93	17,05	19,73	22,32	24,48	9,38	10,85	12,27	13,47
	325	12 3/4	304	335	20,43	23,64	26,75	29,35	18,58	21,49	24,32	26,68	10,22	11,82	13,37	14,67
	350	13 3/4	329	360	22,11	25,59	28,95	31,76	20,10	23,26	26,32	28,87	11,06	12,79	14,47	15,88
	375	14 3/4	354	385	23,79	27,53	31,15	34,17	21,63	25,03	28,32	31,07	11,90	13,77	15,57	17,09
	400	15 3/4	379	410	25,47	29,47	33,35	36,58	23,16	26,80	30,32	33,26	12,74	14,74	16,67	18,29
	425	16 3/4	404	435	27,15	31,42	35,55	39,00	24,69	28,56	32,32	35,45	13,58	15,71	17,77	19,50
	450	17 3/4	429	460	28,83	33,36	37,75	41,41	26,21	30,33	34,32	37,65	14,42	16,68	18,87	20,71
	475	18 11/16	454	485	30,52	35,31	39,95	43,82	27,74	32,10	36,32	39,84	15,26	17,65	19,97	21,91
	500	19 3/4	479	510	32,20	37,25	42,15	46,24	29,27	33,87	38,32	42,03	16,10	18,63	21,07	23,12
525	20 11/16	504	535	33,88	39,20	44,35	48,65	30,80	35,63	40,32	44,23	16,94	19,60	22,17	24,33	
550	21 5/8	529	560	35,56	41,14	46,55	51,06	32,32	37,40	42,32	46,42	17,78	20,57	23,27	25,53	

geometry					TENSION/COMPRESSION ⁽¹⁾											
					$\alpha = 90^\circ$				total thread withdrawal $\alpha = 45^\circ$				end grain $\alpha = 0^\circ$			
					factored withdrawal resistance P_{rw}				factored withdrawal resistance P_{rw}				factored withdrawal resistance P_{rw} ⁽²⁾			
					G				G				G			
d_1	L	$S_{g,tot}$	A_{min}		0.35	0.42	0.49	0.55	0.35	0.42	0.49	0.55	0.35	0.42	0.49	0.55
[mm] [in]	[mm] [in]	[mm]	[mm]		[kN]	[kN]	[kN]	[kN]	[kN]	[kN]	[kN]	[kN]	[kN]	[kN]	[kN]	[kN]
11 0.44	575	22 5/8	554	585	37,24	43,08	48,75	53,48	33,85	39,17	44,31	48,62	18,62	21,54	24,37	26,74
	600	23 5/8	579	610	38,92	45,03	50,95	55,89	35,38	40,94	46,31	50,81	19,46	22,51	25,47	27,95
	650	25 9/16	619	660	41,61	48,14	54,47	59,75	37,82	43,76	49,51	54,32	20,80	24,07	27,23	29,88
	700	27 1/2	669	710	44,97	52,03	58,87	64,58	40,88	47,30	53,51	58,71	22,48	26,01	29,43	32,29
	750	29 1/2	719	760	48,33	55,92	63,26	69,41	43,93	50,83	57,51	63,10	24,16	27,96	31,63	34,70
	800	31 1/2	769	810	51,69	59,81	67,66	74,23	46,99	54,37	61,51	67,48	25,84	29,90	33,83	37,12
	850	33 7/16	819	860	55,05	63,69	72,06	79,06	50,04	57,90	65,51	71,87	27,52	31,85	36,03	39,53
	900	35 1/2	869	910	58,41	67,58	76,46	83,88	53,10	61,44	69,51	76,26	29,20	33,79	38,23	41,94
	950	37 3/8	919	960	61,77	71,47	80,86	88,71	56,15	64,97	73,51	80,65	30,88	35,74	40,43	44,36
	1000	39 3/8	969	1010	65,13	75,36	85,26	93,54	59,21	68,51	77,51	85,03	32,57	37,68	42,63	46,77
13 0.52	80	3 1/8	57	90	4,53	5,25	5,93	6,50	4,12	4,77	5,39	5,91	2,26	2,62	2,96	3,25
	100	4	77	110	6,12	7,09	8,00	8,78	5,56	6,44	7,28	7,98	3,06	3,54	4,00	4,39
	150	6	127	160	10,09	11,69	13,20	14,48	9,17	10,63	12,00	13,17	5,05	5,85	6,60	7,24
	200	8	177	210	14,06	16,29	18,40	20,18	12,78	14,81	16,73	18,35	7,03	8,15	9,20	10,09
	250	10	227	260	18,04	20,90	23,60	25,88	16,40	19,00	21,45	23,53	9,02	10,45	11,80	12,94
	300	11 3/4	267	310	21,21	24,58	27,75	30,45	19,28	22,34	25,23	27,68	10,61	12,29	13,88	15,22
	350	13 3/4	317	360	25,19	29,18	32,95	36,15	22,90	26,53	29,96	32,86	12,59	14,59	16,48	18,07
	400	15 3/4	367	410	29,16	33,78	38,15	41,85	26,51	30,71	34,68	38,04	14,58	16,89	19,07	20,92
	450	17 3/4	417	460	33,13	38,38	43,35	47,55	30,12	34,90	39,41	43,23	16,57	19,19	21,67	23,78
	500	19 3/4	467	510	37,10	42,99	48,54	53,25	33,73	39,08	44,13	48,41	18,55	21,49	24,27	26,63
	550	21 5/8	517	560	41,08	47,59	53,74	58,95	37,34	43,26	48,86	53,59	20,54	23,79	26,87	29,48
	600	23 5/8	567	610	45,05	52,19	58,94	64,66	40,95	47,45	53,58	58,78	22,52	26,10	29,47	32,33
	650	25 9/16	617	660	49,02	56,79	64,14	70,36	44,56	51,63	58,31	63,96	24,51	28,40	32,07	35,18
	700	27 1/2	667	710	52,99	61,40	69,33	76,06	48,18	55,82	63,03	69,14	26,50	30,70	34,67	38,03
	750	29 1/2	717	760	56,97	66,00	74,53	81,76	51,79	60,00	67,76	74,33	28,48	33,00	37,27	40,88
	800	31 1/2	767	810	60,94	70,60	79,73	87,46	55,40	64,18	72,48	79,51	30,47	35,30	39,86	43,73
	850	33 7/16	817	860	64,91	75,20	84,93	93,16	59,01	68,37	77,21	84,69	32,46	37,60	42,46	46,58
900	35 1/2	867	910	68,88	79,81	90,12	98,86	62,62	72,55	81,93	89,88	34,44	39,90	45,06	49,43	
950	37 3/8	917	960	72,86	84,41	95,32	104,57	66,23	76,74	86,66	95,06	36,43	42,20	47,66	52,28	
1000	39 3/8	967	1010	76,83	89,01	100,52	110,27	69,84	80,92	91,38	100,24	38,41	44,51	50,26	55,13	
1100	43 5/16	1067	1110	84,77	98,22	110,91	121,67	77,07	89,29	100,83	110,61	42,39	49,11	55,46	60,84	
1200	47 1/4	1167	1210	92,72	107,42	121,31	133,07	84,29	97,66	110,28	120,98	46,36	53,71	60,65	66,54	
1300	51 3/16	1267	1310	100,66	116,63	131,70	144,48	91,51	106,02	119,73	131,34	50,33	58,31	65,85	72,24	
1400	55 1/8	1367	1410	108,61	125,83	142,10	155,88	98,73	114,39	129,18	141,71	54,30	62,92	71,05	77,94	
1500	59 1/16	1467	1510	116,55	135,04	152,49	167,28	105,96	122,76	138,63	152,07	58,28	67,52	76,25	83,64	

α = screw-to-grain angle

NOTES and GENERAL PRINCIPLES on page 17.

geometry					TENSION/COMPRESSION ⁽¹⁾								steel tension	buckling $\alpha = 90^\circ$
					partial thread withdrawal $\alpha = 90^\circ$				end grain $\alpha = 0^\circ$					
					factored withdrawal resistance P_{rw}				factored withdrawal resistance $P_{rw}^{(2)}$				factored tension resistance T_{rs}	factored buckling resistance P_{rb}
d_1 [mm] [in]	L		S_g [mm]	A_{min} [mm]	G				G				[kN]	[kN]
	[mm]	[in]			0.35	0.42	0.49	0.55	0.35	0.42	0.49	0.55		
9 0.36	100	4	35,0	55	1,92	2,23	2,52	2,76	0,96	1,11	1,26	1,38	17,84	16,37
	120	4 3/4	45,0	65	2,47	2,86	3,24	3,55	1,24	1,43	1,62	1,78		
	140	5 1/2	55,0	75	3,02	3,50	3,96	4,34	1,51	1,75	1,98	2,17		
	160	6 1/4	65,0	85	3,57	4,14	4,68	5,13	1,79	2,07	2,34	2,57		
	180	7 1/8	75,0	95	4,12	4,77	5,40	5,92	2,06	2,39	2,70	2,96		
	200	8	85,0	105	4,67	5,41	6,12	6,71	2,34	2,70	3,06	3,36		
	220	8 5/8	95,0	115	5,22	6,04	6,84	7,50	2,61	3,02	3,42	3,75		
	240	9 1/2	105,0	125	5,77	6,68	7,56	8,29	2,89	3,34	3,78	4,15		
	260	10 1/4	115,0	135	6,32	7,32	8,28	9,08	3,16	3,66	4,14	4,54		
	280	11	125,0	145	6,87	7,95	9,00	9,87	3,44	3,98	4,50	4,94		
	300	11 3/4	135,0	155	7,42	8,59	9,71	10,66	3,71	4,30	4,86	5,33		
	320	12 5/8	145,0	165	7,97	9,23	10,43	11,45	3,99	4,61	5,22	5,72		
	340	13 3/8	155,0	175	8,52	9,86	11,15	12,24	4,26	4,93	5,58	6,12		
	360	14 1/4	165,0	185	9,07	10,50	11,87	13,03	4,54	5,25	5,94	6,51		
	380	15	175,0	195	9,62	11,14	12,59	13,82	4,81	5,57	6,30	6,91		
	400	15 3/4	185,0	205	10,17	11,77	13,31	14,61	5,09	5,89	6,66	7,30		
	440	17 1/4	205,0	225	11,27	13,04	14,75	16,19	5,64	6,52	7,38	8,09		
	480	19	225,0	245	12,37	14,32	16,19	17,77	6,19	7,16	8,10	8,88		
520	20 1/2	245,0	265	13,47	15,59	17,63	19,35	6,74	7,79	8,82	9,67			
560	22	265,0	285	14,57	16,86	19,07	20,92	7,29	8,43	9,53	10,46			
600	23 5/8	285,0	305	15,67	18,13	20,51	22,50	7,84	9,07	10,25	11,25			
11 0.44	80	3 1/8	25,0	45	1,68	1,94	2,20	2,41	0,84	0,97	1,10	1,21	23,17	19,66
	100	4	35,0	55	2,35	2,72	3,08	3,38	1,18	1,36	1,54	1,69		
	125	4 15/16	45,0	68	3,02	3,50	3,96	4,34	1,51	1,75	1,98	2,17		
	150	6	60,0	80	4,03	4,67	5,28	5,79	2,02	2,33	2,64	2,90		
	175	6 7/8	70,0	93	4,70	5,44	6,16	6,76	2,35	2,72	3,08	3,38		
	200	8	85,0	105	5,71	6,61	7,48	8,21	2,86	3,31	3,74	4,10		
	225	8 7/8	95,0	118	6,39	7,39	8,36	9,17	3,19	3,69	4,18	4,59		
	250	10	110,0	130	7,39	8,55	9,68	10,62	3,70	4,28	4,84	5,31		
	275	10 7/8	120,0	143	8,07	9,33	10,56	11,58	4,03	4,67	5,28	5,79		
	300	11 3/4	135,0	155	9,07	10,50	11,88	13,03	4,54	5,25	5,94	6,52		
	325	12 3/4	145,0	168	9,75	11,28	12,76	14,00	4,87	5,64	6,38	7,00		
	350	13 3/4	160,0	180	10,75	12,44	14,08	15,44	5,38	6,22	7,04	7,72		
	375	14 3/4	170,0	193	11,43	13,22	14,96	16,41	5,71	6,61	7,48	8,21		
	400	15 3/4	185,0	205	12,43	14,39	16,28	17,86	6,22	7,19	8,14	8,93		
	425	16 3/4	195,0	218	13,11	15,17	17,16	18,82	6,55	7,58	8,58	9,41		
	450	17 3/4	210,0	230	14,11	16,33	18,48	20,27	7,06	8,17	9,24	10,14		
	475	18 11/16	220,0	243	14,79	17,11	19,36	21,24	7,39	8,55	9,68	10,62		
	500	19 3/4	235,0	255	15,80	18,28	20,68	22,68	7,90	9,14	10,34	11,34		
525	20 11/16	245,0	268	16,47	19,05	21,56	23,65	8,23	9,53	10,78	11,82			
550	21 5/8	260,0	280	17,48	20,22	22,88	25,10	8,74	10,11	11,44	12,55			

geometry					TENSION/COMPRESSION ⁽¹⁾											
					partial thread withdrawal $\alpha = 90^\circ$				end grain $\alpha = 0^\circ$				steel tension		buckling $\alpha = 90^\circ$	
					factored withdrawal resistance P_{rw}				factored withdrawal resistance $P_{rw}^{(2)}$				factored tension resistance T_{rs}		factored buckling resistance P_{rb}	
					G				G							
d_1	L		S_g	A_{min}	0.35	0.42	0.49	0.55	0.35	0.42	0.49	0.55				
[mm] [in]	[mm]	[in]	[mm]	[mm]	[kN]	[kN]	[kN]	[kN]	[kN]	[kN]	[kN]	[kN]	[kN]		[kN]	
11 0.44	575	22 5/8	270,0	293	18,15	21,00	23,76	26,06	9,07	10,50	11,88	13,03	23,17		19,66	
	600	23 5/8	285,0	305	19,16	22,16	25,08	27,51	9,58	11,08	12,54	13,76				
	650	25 9/16	305,0	330	20,50	23,72	26,84	29,44	10,25	11,86	13,42	14,72				
	700	27 1/2	330,0	355	22,18	25,66	29,04	31,85	11,09	12,83	14,52	15,93				
	750	29 1/2	355,0	380	23,86	27,61	31,24	34,27	11,93	13,80	15,62	17,13				
	800	31 1/2	380,0	405	25,54	29,55	33,44	36,68	12,77	14,78	16,72	18,34				
	850	33 7/16	405,0	430	27,22	31,50	35,64	39,09	13,61	15,75	17,82	19,55				
	900	35 1/2	430,0	455	28,90	33,44	37,84	41,51	14,45	16,72	18,92	20,75				
	950	37 3/8	455,0	480	30,58	35,39	40,04	43,92	15,29	17,69	20,02	21,96				
	1000	39 3/8	480,0	505	32,26	37,33	42,24	46,33	16,13	18,66	21,12	23,17				
13 0.52	80	3 1/8	25,0	45	1,99	2,30	2,60	2,85	0,99	1,15	1,30	1,43	31,96		27,02	
	100	4	35,0	55	2,78	3,22	3,64	3,99	1,39	1,61	1,82	2,00				
	150	6	60,0	80	4,77	5,52	6,24	6,84	2,38	2,76	3,12	3,42				
	200	8	85,0	105	6,75	7,82	8,84	9,69	3,38	3,91	4,42	4,85				
	250	10	110,0	130	8,74	10,13	11,43	12,54	4,37	5,06	5,72	6,27				
	300	11 3/4	130,0	155	10,33	11,97	13,51	14,82	5,16	5,98	6,76	7,41				
	350	13 3/4	155,0	180	12,31	14,27	16,11	17,67	6,16	7,13	8,06	8,84				
	400	15 3/4	180,0	205	14,30	16,57	18,71	20,53	7,15	8,28	9,36	10,26				
	450	17 3/4	205,0	230	16,29	18,87	21,31	23,38	8,14	9,44	10,65	11,69				
	500	19 3/4	230,0	255	18,27	21,17	23,91	26,23	9,14	10,59	11,95	13,11				
	550	21 5/8	255,0	280	20,26	23,47	26,51	29,08	10,13	11,74	13,25	14,54				
	600	23 5/8	280,0	305	22,25	25,77	29,11	31,93	11,12	12,89	14,55	15,96				
	650	25 9/16	305,0	330	24,23	28,08	31,70	34,78	12,12	14,04	15,85	17,39				
	700	27 1/2	330,0	355	26,22	30,38	34,30	37,63	13,11	15,19	17,15	18,81				
	750	29 1/2	355,0	380	28,20	32,68	36,90	40,48	14,10	16,34	18,45	20,24				
	800	31 1/2	380,0	405	30,19	34,98	39,50	43,33	15,10	17,49	19,75	21,67				
	850	33 7/16	405,0	430	32,18	37,28	42,10	46,18	16,09	18,64	21,05	23,09				
	900	35 1/2	430,0	455	34,16	39,58	44,70	49,03	17,08	19,79	22,35	24,52				
	950	37 3/8	455,0	480	36,15	41,88	47,30	51,88	18,07	20,94	23,65	25,94				
	1000	39 3/8	480,0	505	38,14	44,18	49,90	54,73	19,07	22,09	24,95	27,37				
1100	43 5/16	530,0	555	42,11	48,79	55,09	60,44	21,05	24,39	27,55	30,22					
1200	47 1/4	580,0	605	46,08	53,39	60,29	66,14	23,04	26,69	30,15	33,07					
1300	51 3/16	630,0	655	50,05	57,99	65,49	71,84	25,03	29,00	32,74	35,92					
1400	55 1/8	680,0	705	54,03	62,59	70,69	77,54	27,01	31,30	35,34	38,77					
1500	59 1/16	730,0	755	58,00	67,20	75,88	83,24	29,00	33,60	37,94	41,62					

α = screw-to-grain angle

NOTES and GENERAL PRINCIPLES on page 17.

geometry		timber-to-timber				steel-to-timber								steel tension			
d ₁ [mm] [in]	L [mm] [in]	S _g [mm]	A [mm]	B _{min} [mm]	factored lateral resistance N _r ⁽⁴⁾				S _{PLATE} ⁽⁵⁾ [mm] [in]	S _g [mm]	A _{min} [mm]	factored lateral resistance N _r ⁽⁴⁾				factored tension resistance T _{rs}	
					G							G				[kN]	
					0.35	0.42	0.49	0.55				0.35	0.42	0.49	0.55	[kN]	
9 0.36	100	4	35	40	55	1,48	1,72	1,94	2,13	15,9 5/8	70	70	2,97	3,44	3,89	4,26	12,61
	120	4 3/4	45	45	60	1,91	2,21	2,50	2,74		90	85	3,82	4,42	5,00	5,48	
	140	5 1/2	55	55	70	2,33	2,70	3,05	3,35		110	100	4,67	5,40	6,11	6,70	
	160	6 1/4	65	60	75	2,76	3,19	3,61	3,96		130	115	5,51	6,38	7,22	7,92	
	180	7 1/8	75	70	85	3,18	3,68	4,16	4,57		150	125	6,36	7,36	8,33	9,14	
	200	8	85	75	90	3,61	4,17	4,72	5,18		170	140	7,21	8,34	9,44	10,35	
	220	8 5/8	95	80	95	4,03	4,66	5,27	5,79		190	155	8,06	9,33	10,55	11,57	
	240	9 1/2	105	90	105	4,45	5,15	5,83	6,40		210	170	8,91	10,31	11,66	12,79	
	260	10 1/4	115	95	110	4,88	5,64	6,38	7,00		230	185	9,76	11,29	12,77	14,01	
	280	11	125	105	120	5,30	6,14	6,94	7,61		250	200	10,61	12,27	13,88	15,23	
	300	11 3/4	135	110	125	5,73	6,63	7,49	8,22		270	210	11,45	13,25	14,99	16,45	
	320	12 5/8	145	115	130	6,15	7,12	8,05	8,83		290	225	12,30	14,23	16,10	17,66	
	340	13 3/8	155	125	140	6,58	7,61	8,60	9,44		310	240	13,15	15,22	17,21	18,88	
	360	14 1/4	165	130	145	7,00	8,10	9,16	10,05		330	255	14,00	16,20	18,32	20,10	
	380	15	175	140	155	7,42	8,59	9,71	10,66		350	270	14,85	17,18	19,43	21,32	
	400	15 3/4	185	145	160	7,85	9,08	10,27	11,27		370	285	15,70	18,16	20,54	22,54	
	440	17 1/4	205	160	175	8,70	10,06	11,38	12,49		410	310	17,39	20,12	22,76	24,97	
	480	19	225	175	190	9,54	11,04	12,49	13,70		450	340	19,09	22,09	24,98	27,41	
	520	20 1/2	245	190	205	10,39	12,03	13,60	14,92		490	370	20,79	24,05	27,20	29,85	
	560	22	265	200	215	11,24	13,01	14,71	16,14		530	395	22,48	26,01	29,42	32,28	
600	23 5/8	285	215	230	12,09	13,99	15,82	17,36	570	425	24,18	27,98	31,64	34,72			
11 0.44	80	3 1/8	25	35	50	1,30	1,50	1,70	1,86	19,1 3/4	40	50	2,07	2,40	2,71	2,98	16,38
	100	4	35	40	55	1,81	2,10	2,38	2,61		60	65	3,11	3,60	4,07	4,47	
	125	4 15/16	45	50	65	2,33	2,70	3,05	3,35		85	85	4,41	5,10	5,77	6,33	
	150	6	60	60	75	3,11	3,60	4,07	4,47		110	100	5,70	6,60	7,47	8,19	
	175	6 7/8	70	65	80	3,63	4,20	4,75	5,21		135	120	7,00	8,10	9,16	10,05	
	200	8	85	75	90	4,41	5,10	5,77	6,33		160	135	8,30	9,60	10,86	11,91	
	225	8 7/8	95	85	100	4,93	5,70	6,45	7,07		185	155	9,59	11,10	12,56	13,78	
	250	10	110	95	110	5,70	6,60	7,47	8,19		210	170	10,89	12,60	14,25	15,64	
	275	10 7/8	120	100	115	6,22	7,20	8,14	8,94		235	190	12,18	14,10	15,95	17,50	
	300	11 3/4	135	110	125	7,00	8,10	9,16	10,05		260	205	13,48	15,60	17,65	19,36	
	325	12 3/4	145	120	135	7,52	8,70	9,84	10,80		285	225	14,78	17,10	19,34	21,22	
	350	13 3/4	160	130	145	8,30	9,60	10,86	11,91		310	240	16,07	18,60	21,04	23,08	
	375	14 3/4	170	135	150	8,81	10,20	11,54	12,66		335	260	17,37	20,10	22,74	24,94	
	400	15 3/4	185	145	160	9,59	11,10	12,56	13,78		360	275	18,67	21,60	24,43	26,81	
	425	16 3/4	195	155	170	10,11	11,70	13,24	14,52		385	295	19,96	23,10	26,13	28,67	
	450	17 3/4	210	165	180	10,89	12,60	14,25	15,64		410	315	21,26	24,60	27,83	30,53	
	475	18 11/16	220	170	185	11,41	13,20	14,93	16,38		435	330	22,55	26,10	29,53	32,39	
	500	19 3/4	235	180	195	12,18	14,10	15,95	17,50		460	350	23,85	27,60	31,22	34,25	
	525	20 11/16	245	190	205	12,70	14,70	16,63	18,24		485	365	25,15	29,10	32,92	36,11	
	550	21 5/8	260	200	215	13,48	15,60	17,65	19,36		510	385	26,44	30,60	34,62	37,98	

SLIDING⁽³⁾

geometry		timber-to-timber					steel-to-timber					steel tension					
d ₁ [mm] [in]	L		S _g [mm]	A [mm]	B _{min} [mm]	factored lateral resistance N _r ⁽⁴⁾				S _{PLATE} ^{(5) [mm] [in]}	S _g [mm]	A _{min} [mm]	factored lateral resistance N _r ⁽⁴⁾				factored tension resistance T _{rs} [kN]
	[mm]	[in]				G							G				
						0.35	0.42	0.49	0.55				0.35	0.42	0.49	0.55	
11 <i>0.44</i>	575	22 5/8	270	205	220	14,00	16,20	18,33	20,10	19,1 3/4	535	400	27,74	32,10	36,31	39,84	16,38
	600	23 5/8	285	220	235	14,78	17,10	19,34	21,22		560	420	29,03	33,59	38,01	41,70	
	650	25 9/16	305	230	245	15,81	18,30	20,70	22,71		-	-	-	-	-	-	
	700	27 1/2	330	250	265	17,11	19,80	22,40	24,57		-	-	-	-	-	-	
	750	29 1/2	355	265	280	18,41	21,30	24,10	26,43		-	-	-	-	-	-	
	800	31 1/2	380	285	300	19,70	22,80	25,79	28,30		-	-	-	-	-	-	
	850	33 7/16	405	305	320	21,00	24,30	27,49	30,16		-	-	-	-	-	-	
	900	35 1/2	430	320	335	22,29	25,80	29,19	32,02		-	-	-	-	-	-	
	950	37 3/8	455	340	355	23,59	27,30	30,88	33,88		-	-	-	-	-	-	
	1000	39 3/8	480	355	370	24,89	28,80	32,58	35,74		-	-	-	-	-	-	
13 <i>0.52</i>	80	3 1/8	25	35	50	1,53	1,78	2,00	2,20	22,2 7/8	35	50	2,15	2,49	2,81	3,08	22,60
	100	4	35	40	55	2,15	2,49	2,81	3,08		55	65	3,37	3,91	4,41	4,84	
	150	6	60	60	75	3,68	4,26	4,81	5,28		105	100	6,44	7,46	8,42	9,24	
	200	8	85	80	95	5,21	6,04	6,82	7,48		155	135	9,50	11,01	12,43	13,63	
	250	10	110	95	110	6,74	7,81	8,82	9,68		205	170	12,56	14,56	16,44	18,03	
	300	11 3/4	130	110	125	7,97	9,23	10,42	11,43		255	205	15,63	18,11	20,45	22,43	
	350	13 3/4	155	125	140	9,50	11,01	12,43	13,63		305	240	18,69	21,66	24,46	26,83	
	400	15 3/4	180	145	160	11,03	12,78	14,43	15,83		355	275	21,76	25,21	28,47	31,23	
	450	17 3/4	205	165	180	12,56	14,56	16,44	18,03		405	310	24,82	28,76	32,48	35,62	
	500	19 3/4	230	180	195	14,10	16,33	18,44	20,23		455	345	27,89	32,31	36,48	40,02	
	550	21 5/8	255	200	215	15,63	18,11	20,45	22,43		505	380	30,95	35,86	40,49	44,42	
	600	23 5/8	280	215	230	17,16	19,88	22,45	24,63		555	415	34,01	39,41	44,50	48,82	
	650	25 9/16	305	235	250	18,69	21,66	24,46	26,83		-	-	-	-	-	-	
	700	27 1/2	330	250	265	20,22	23,43	26,46	29,03		-	-	-	-	-	-	
	750	29 1/2	355	270	285	21,76	25,21	28,47	31,23		-	-	-	-	-	-	
	800	31 1/2	380	285	300	23,29	26,98	30,47	33,43		-	-	-	-	-	-	
	850	33 7/16	405	305	320	24,82	28,76	32,48	35,62		-	-	-	-	-	-	
	900	35 1/2	430	320	335	26,35	30,53	34,48	37,82		-	-	-	-	-	-	
	950	37 3/8	455	340	355	27,89	32,31	36,48	40,02		-	-	-	-	-	-	
	1000	39 3/8	480	355	370	29,42	34,08	38,49	42,22		-	-	-	-	-	-	
1100	43 5/16	530	390	405	32,48	37,63	42,50	46,62	-	-	-	-	-	-			
1200	47 1/4	580	430	445	35,55	41,18	46,51	51,02	-	-	-	-	-	-			
1300	51 3/16	630	465	480	38,61	44,73	50,52	55,42	-	-	-	-	-	-			
1400	55 1/8	680	500	515	41,68	48,28	54,53	59,81	-	-	-	-	-	-			
1500	59 1/16	730	535	550	44,74	51,83	58,54	64,21	-	-	-	-	-	-			

NOTES and GENERAL PRINCIPLES on page 17.

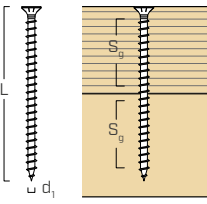
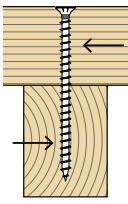
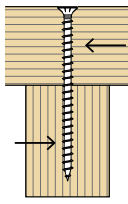
geometry					SHEAR ^[6]							
					timber-to-timber							
					$\alpha = 90^\circ$				$\alpha = 0^\circ$			
												
					factored lateral resistance N_r				factored lateral resistance $N_r^{(2)}$			
					G				G			
d_1	L		S_g	$A^{(7)}$	0.35	0.42	0.49	0.55	0.35	0.42	0.49	0.55
[mm] [in]	[mm]	[in]	[mm]	[mm]	[kN]	[kN]	[kN]	[kN]	[kN]	[kN]	[kN]	[kN]
9 0.36	100	4	35	50	1,78	2,12	2,45	2,74	1,16	1,38	1,56	1,69
	120	4 3/4	45	60	2,18	2,59	3,00	3,34	1,37	1,55	1,73	1,87
	140	5 1/2	55	70	2,58	3,01	3,30	3,53	1,49	1,69	1,89	2,05
	160	6 1/4	65	80	2,85	3,17	3,48	3,73	1,61	1,83	2,05	2,23
	180	7 1/8	75	90	2,98	3,33	3,66	3,93	1,73	1,98	2,21	2,41
	200	8	85	100	3,12	3,49	3,84	4,13	1,85	2,12	2,38	2,59
	220	8 5/8	95	110	3,26	3,65	4,02	4,32	1,97	2,26	2,54	2,77
	240	9 1/2	105	120	3,40	3,81	4,20	4,52	2,09	2,40	2,70	2,90
	260	10 1/4	115	130	3,53	3,97	4,38	4,72	2,21	2,54	2,79	3,00
	280	11	125	140	3,67	4,13	4,56	4,90	2,33	2,62	2,88	3,09
	300	11 3/4	135	150	3,81	4,28	4,62	4,90	2,41	2,70	2,97	3,19
	320	12 5/8	145	160	3,91	4,28	4,62	4,90	2,48	2,78	3,06	3,29
	340	13 3/8	155	170	3,91	4,28	4,62	4,90	2,55	2,86	3,15	3,39
	360	14 1/4	165	180	3,91	4,28	4,62	4,90	2,62	2,94	3,24	3,49
	380	15	175	190	3,91	4,28	4,62	4,90	2,69	3,02	3,33	3,59
	400	15 3/4	185	200	3,91	4,28	4,62	4,90	2,76	3,10	3,42	3,69
	440	17 1/4	205	220	3,91	4,28	4,62	4,90	2,89	3,24	3,49	3,70
	480	19	225	240	3,91	4,28	4,62	4,90	2,95	3,24	3,49	3,70
520	20 1/2	245	260	3,91	4,28	4,62	4,90	2,95	3,24	3,49	3,70	
560	22	265	280	3,91	4,28	4,62	4,90	2,95	3,24	3,49	3,70	
600	23 5/8	285	300	3,91	4,28	4,62	4,90	2,95	3,24	3,49	3,70	
11 0.44	80	3 1/8	25	40	1,60	1,91	2,21	2,47	1,04	1,24	1,44	1,61
	100	4	35	50	2,07	2,46	2,85	3,18	1,34	1,59	1,84	2,03
	125	4 15/16	45	63	2,66	3,15	3,65	4,07	1,68	1,91	2,12	2,30
	150	6	60	75	3,24	3,81	4,17	4,47	1,86	2,12	2,37	2,57
	175	6 7/8	70	88	3,63	4,05	4,45	4,77	2,04	2,33	2,61	2,84
	200	8	85	100	3,84	4,29	4,72	5,07	2,22	2,54	2,85	3,11
	225	8 7/8	95	113	4,05	4,54	5,00	5,37	2,40	2,75	3,09	3,38
	250	10	110	125	4,26	4,78	5,27	5,68	2,58	2,97	3,34	3,62
	275	10 7/8	120	138	4,47	5,02	5,55	5,98	2,76	3,18	3,51	3,77
	300	11 3/4	135	150	4,68	5,27	5,75	6,09	2,94	3,31	3,65	3,92
	325	12 3/4	145	163	4,86	5,32	5,75	6,09	3,07	3,44	3,78	4,07
	350	13 3/4	160	175	4,86	5,32	5,75	6,09	3,17	3,56	3,92	4,22
	375	14 3/4	170	188	4,86	5,32	5,75	6,09	3,28	3,68	4,06	4,37
	400	15 3/4	185	200	4,86	5,32	5,75	6,09	3,38	3,80	4,20	4,52
	425	16 3/4	195	213	4,86	5,32	5,75	6,09	3,49	3,92	4,33	4,60
	450	17 3/4	210	225	4,86	5,32	5,75	6,09	3,59	4,02	4,35	4,60
	475	18 11/16	220	238	4,86	5,32	5,75	6,09	3,67	4,02	4,35	4,60
	500	19 3/4	235	250	4,86	5,32	5,75	6,09	3,67	4,02	4,35	4,60
525	20 11/16	245	263	4,86	5,32	5,75	6,09	3,67	4,02	4,35	4,60	
550	21 5/8	260	275	4,86	5,32	5,75	6,09	3,67	4,02	4,35	4,60	

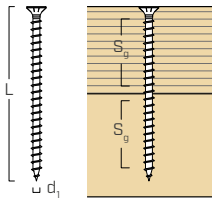
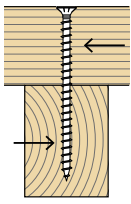
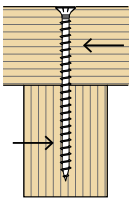
geometry					SHEAR ^[6]							
					timber-to-timber				timber-to-timber			
					$\alpha = 90^\circ$				$\alpha = 0^\circ$			
												
d₁ L S_g A⁽⁷⁾					factored lateral resistance N _r				factored lateral resistance N _r ⁽²⁾			
					G				G			
[mm] [in]	[mm] [in]	[mm] [in]	[mm] [in]	[mm] [in]	0.35 [kN]	0.42 [kN]	0.49 [kN]	0.55 [kN]	0.35 [kN]	0.42 [kN]	0.49 [kN]	0.55 [kN]
11 0.44	575	22 5/8	270	288	4,86	5,32	5,75	6,09	3,67	4,02	4,35	4,60
	600	23 5/8	285	300	4,86	5,32	5,75	6,09	3,67	4,02	4,35	4,60
	650	25 9/16	300	325	4,86	5,32	5,75	6,09	3,67	4,02	4,35	4,60
	700	27 1/2	325	350	4,86	5,32	5,75	6,09	3,67	4,02	4,35	4,60
	750	29 1/2	350	375	4,86	5,32	5,75	6,09	3,67	4,02	4,35	4,60
	800	31 1/2	375	400	4,86	5,32	5,75	6,09	3,67	4,02	4,35	4,60
	850	33 7/16	400	425	4,86	5,32	5,75	6,09	3,67	4,02	4,35	4,60
	900	35 1/2	425	450	4,86	5,32	5,75	6,09	3,67	4,02	4,35	4,60
	950	37 3/8	450	475	4,86	5,32	5,75	6,09	3,67	4,02	4,35	4,60
	1000	39 3/8	475	500	4,86	5,32	5,75	6,09	3,67	4,02	4,35	4,60
13 0.52	80	3 1/8	20	40	1,79	2,13	2,46	2,75	1,16	1,39	1,61	1,80
	100	4	30	50	2,32	2,76	3,19	3,56	1,50	1,78	2,07	2,31
	150	6	55	75	3,66	4,35	5,02	5,60	2,33	2,64	2,94	3,18
	200	8	80	100	4,95	5,53	6,06	6,50	2,75	3,13	3,50	3,80
	250	10	105	125	5,45	6,10	6,71	7,22	3,16	3,62	4,06	4,43
	300	11 3/4	125	150	5,81	6,52	7,18	7,73	3,58	4,11	4,62	5,03
	350	13 3/4	150	175	6,30	7,09	7,83	8,33	4,00	4,56	5,01	5,39
	400	15 3/4	175	200	6,65	7,28	7,87	8,33	4,32	4,85	5,34	5,74
	450	17 3/4	200	225	6,65	7,28	7,87	8,33	4,57	5,13	5,66	6,10
	500	19 3/4	225	250	6,65	7,28	7,87	8,33	4,82	5,42	5,95	6,30
	550	21 5/8	250	275	6,65	7,28	7,87	8,33	5,03	5,51	5,95	6,30
	600	23 5/8	275	300	6,65	7,28	7,87	8,33	5,03	5,51	5,95	6,30
	650	25 9/16	300	325	6,65	7,28	7,87	8,33	5,03	5,51	5,95	6,30
	700	27 1/2	325	350	6,65	7,28	7,87	8,33	5,03	5,51	5,95	6,30
	750	29 1/2	350	375	6,65	7,28	7,87	8,33	5,03	5,51	5,95	6,30
	800	31 1/2	375	400	6,65	7,28	7,87	8,33	5,03	5,51	5,95	6,30
	850	33 7/16	400	425	6,65	7,28	7,87	8,33	5,03	5,51	5,95	6,30
900	35 1/2	425	450	6,65	7,28	7,87	8,33	5,03	5,51	5,95	6,30	
950	37 3/8	450	475	6,65	7,28	7,87	8,33	5,03	5,51	5,95	6,30	
1000	39 3/8	475	500	6,65	7,28	7,87	8,33	5,03	5,51	5,95	6,30	
1100	43 5/16	525	550	6,65	7,28	7,87	8,33	5,03	5,51	5,95	6,30	
1200	47 1/4	575	600	6,65	7,28	7,87	8,33	5,03	5,51	5,95	6,30	
1300	51 3/16	625	650	6,65	7,28	7,87	8,33	5,03	5,51	5,95	6,30	
1400	55 1/8	675	700	6,65	7,28	7,87	8,33	5,03	5,51	5,95	6,30	
1500	59 1/16	725	750	6,65	7,28	7,87	8,33	5,03	5,51	5,95	6,30	

α = screw-to-grain angle

NOTES and GENERAL PRINCIPLES on page 17.

STRUCTURAL VALUES | FURTHER APPLICATIONS

SHEAR CONNECTION WITH CROSSED CONNECTORS

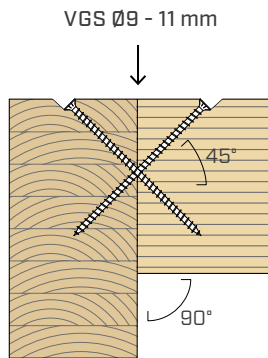

STRUCTURAL VALUES in the Canadian VGZ datasheet.

SLIDING CONNECTION WITH VGU WASHER

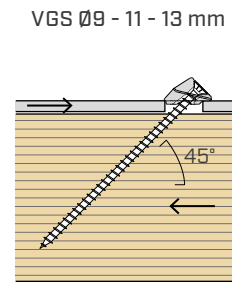

STRUCTURAL VALUES in the Canadian VGU datasheet.

CONNECTIONS WITH CLT ELEMENTS

VGS Ø9 - 11 mm

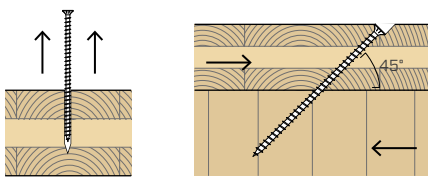

STRUCTURAL VALUES in the Canadian VGZ datasheet.

CONNECTIONS WITH LVL ELEMENTS

VGS Ø9 - 11 mm

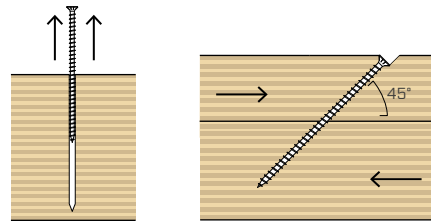

STRUCTURAL VALUES in the European VGZ datasheet.

TC FUSION

TIMBER-TO-CONCRETE JOINT SYSTEM

The innovation of VGS, VGZ and RTR all-thread connectors for timber-concrete applications.

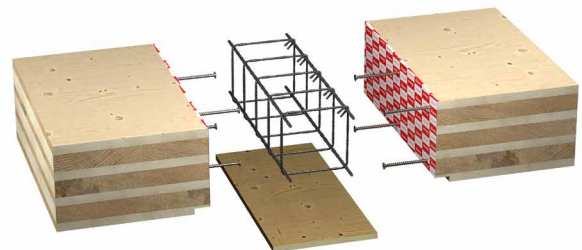

Complete calculation reports for designing in wood?
Download MyProject and simplify your work!



STRUCTURAL VALUES

GENERAL PRINCIPLES

- The reference factored lateral resistance for self-tapping screws has been determined following the guidelines in Clause 12.12 of the CSA-O86 2024 including the withdrawal restraint effect. Listed values are based on standard long term load duration factor ($K_D = 1.0$), dry service condition factor ($K_{SF} = 1.0$), and treatment factor ($K_T = 1.0$).
- The factored thread withdrawal resistance were evaluated considering a penetration length of $S_{g, tot}$ or S_g , as shown in the table. For intermediate values of S_g it is possible to linearly interpolate.
- The reference lateral design values are calculated for screws inserted without pre-drilling hole as per CSA-O86 Clause 12.12.10.5.3. The direction of the bearing-to-grain angle does not influence lateral resistance. In the case of screws inserted with pre-drilling hole, greater resistance values can be obtained.
- The steel plate is assumed to be ASTM A36 with a minimum ultimate tensile strength, f_u , equal to 58 ksi (400 MPa).
- VGS screws must be positioned in accordance with the minimum distances.
- G is the mean relative density according to CSA-O86 2024 Table A12. Most common wood species are assumed such as Northern species ($G = 0.35$), Spruce-Pine-Fir ($G = 0.42$), Douglas Fir ($G = 0.49$), and Southern Pine ($G = 0.55$).
- The tabulated lateral design values are based on both wood members having the same specific gravity G .
- As part of the connection design, the designer must size and verify both the structural wood members and the steel plates separately.
- Combined shear and tensile stresses shall comply with the interaction criteria outlined in CSA-O86 2024 Clause 12.12.11.

NOTES

- (1) Factored withdrawal resistances were calculated with the entire threaded portion of the screw, b (in millimeters), minus the tip length, L_{tip} . The length of the tip is equal to the nominal diameter of the respective fasteners, d_1 , as specified in the ELC-4645 report. Factor for fastener axis-to-grain angle, J_α , and the factor for dowel bearing effect for laterally loaded connections, J_W , varies according to connection geometry.
- (2) The angle between the fastener axis and the grain direction of the wood member, α , is taken as zero for the end grain calculations.
- (3) For fully threaded screws, head pull-through does not govern the connection capacity, instead, thread withdrawal governs. The governing axial resistance is taken as the minimum of the screw's shear, thread withdrawal, and tensile resistances. In this case, the tensile resistance is always lower than the shear resistance, so the governing value is the minimum between thread withdrawal and tensile resistance.
- (4) The 45° inclined screw is intended to work in withdrawal and the resulting resistance of the connection is given by the projection of the withdrawal resistance (along screw axis) onto the shear plane.
- (5) The plate thickness (S_{PLATE}) are understood to be the minimum values to allow the countersunk head of the screw to be accommodated.
- (6) Lateral resistances are factored and according to CSA-O86 2024 Clause 12.12.10. Values apply to dry service conditions and are representative of a single screw.
- (7) The fixable thickness (A) is considered as half the length of the screw ($L/2$).

RELATED PRODUCTS



JIG VGU



LEWIS



CATCH



TORQUE LIMITER



B 13 B

INSTALLATION SUGGESTIONS



LONG SCREWS



Thanks to CATCH, even longer screws can be screwed on quickly and safely without the risk of the bit slipping. Can be combined with TORQUE LIMITER.

VGS + VGU



The JIG VGU template makes it easy to prepare a 45° angle pre-drill, thus facilitating subsequent tightening of the VGS screws inside the washer. A pre-drill length of at least 20 mm is recommended.



To ensure control of the applied torque, the correct TORQUE LIMITER model must be used depending on the chosen connector.

VGS +WASPL



Insert the screw so that the head protrudes 15 mm and engage the WASPL hook.

After lifting, the WASPL hook releases quickly and easily ready for use again.

IMPORTANCE OF THE PILOT HOLE

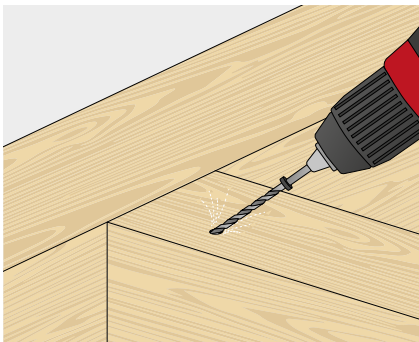

pilot hole

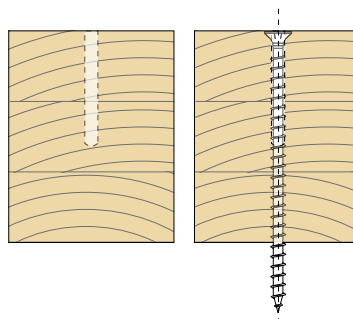

insertion with pilot hole

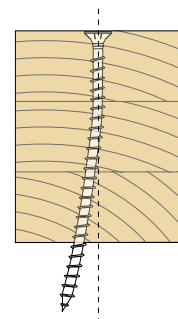

insertion without pilot hole

Deviation of the screw from the direction of screwing often occurs during installation. This phenomenon is linked to the very conformation of the wood material, which is inhomogeneous and non-uniform, e.g. due to the localised presence of knots or physical properties dependent on grain direction. The operator's skill also plays an important role.

The use of pilot holes facilitates the insertion of screws, particularly long ones, allowing a very precise insertion direction.

INSTALLATION INSTRUCTIONS

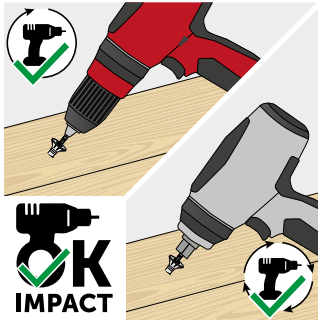

In the case of installation of screws used in timber-to-timber (softwood) structural connections, a pulse screw gun/screw driver can also be used.

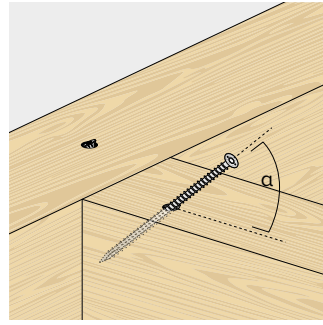

Respect the insertion angle with the help of a pilot hole and/or installation template.

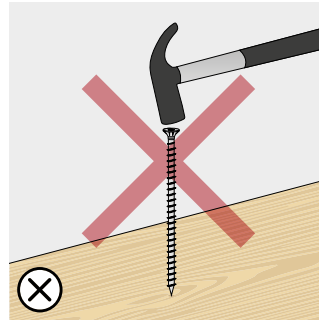

Do not hammer the screw tips into the timber.

The screw cannot be reused.

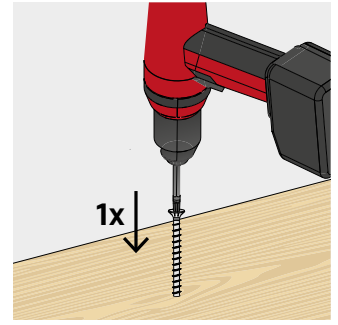

In general, it is recommended to install the connector in a single operation, without stopping and restarting which could create additional stress in the screw.

STEEL-TO-TIMBER APPLICATION



The use of pulse screw guns/impact wrenches is not permitted.

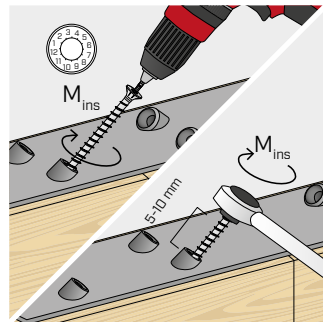

Ensure correct tightening. We recommend the use of torque-controlled screwdrivers, e.g. with TORQUE LIMITER. Alternatively, tighten with a torque wrench.

VGS	d ₁ [mm]	M _{ins,rec} [Nm]
Ø9	9	20
Ø11 L < 400 mm	11	30
Ø11 L ≥ 400 mm	11	40
Ø13	13	50

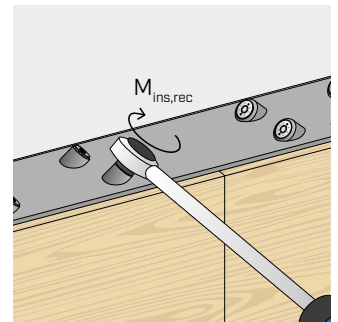

After installation, the fasteners can be inspected using a torque wrench.

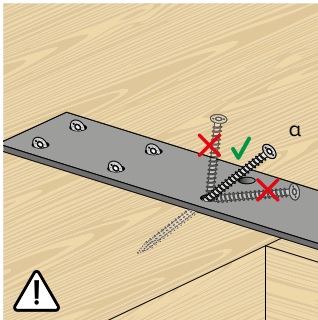

Avoid bending.

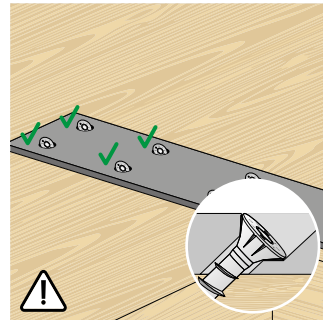

The installation of multiple screws must be performed to guarantee that loads are distributed evenly to all fasteners.

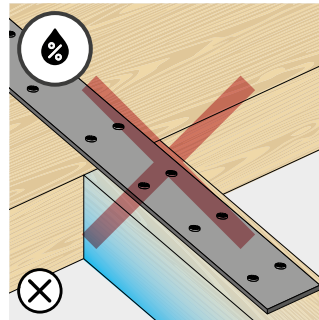

Shrinkage or swelling of timber elements due to changes in moisture content must be avoided.

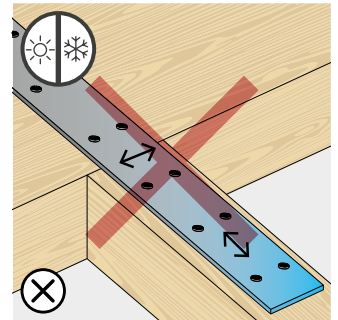

Avoid dimensional changes in the metal, e.g. due to large temperature fluctuations.

SHAPED PLATE

WASHERS

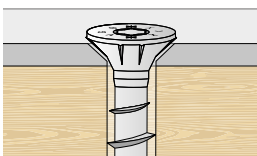

Countersunk hole.

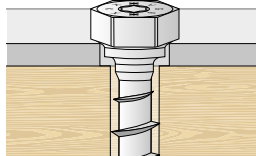

Cylindrical hole.

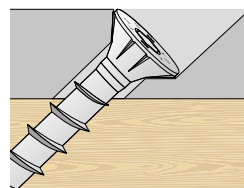

Inclined countersunk hole.

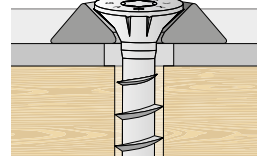

Cylindrical hole with countersunk washer HUS.

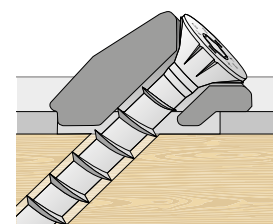

Slotted hole with VGU washer.

APPLICATION EXAMPLES: REINFORCEMENT

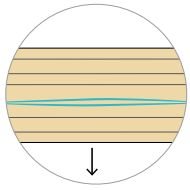

TAPERED BEAMS
apex tension reinforcement perpendicular to grain

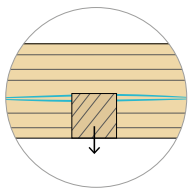
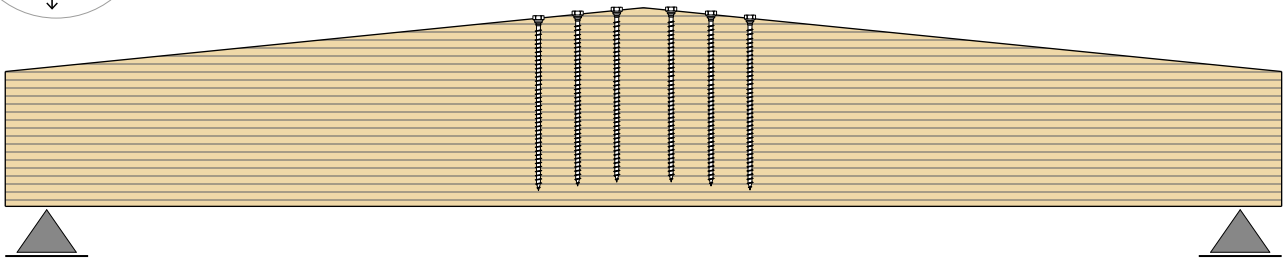

HANGING LOAD
tension reinforcement perpendicular to grain

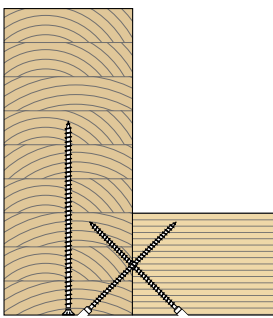

section

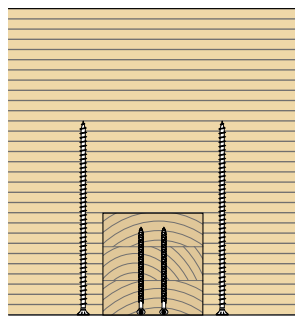

front

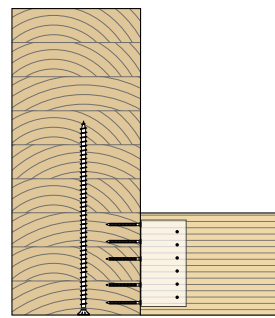

section

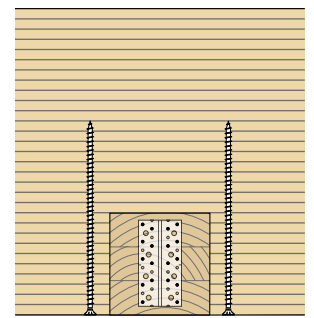

front

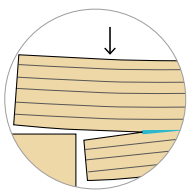

NOTCH
tension reinforcement perpendicular to grain

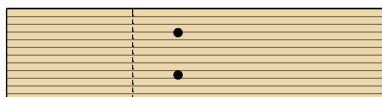

plan

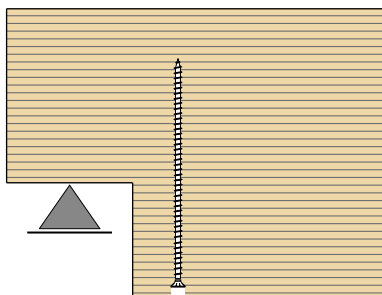

section

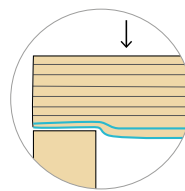

SUPPORT
compression reinforcement perpendicular to grain

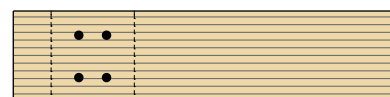

plan

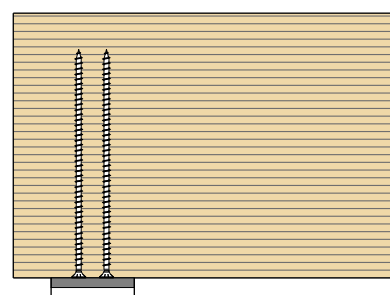

section