

JIG VGZ 45° INSTALLATION MANUAL

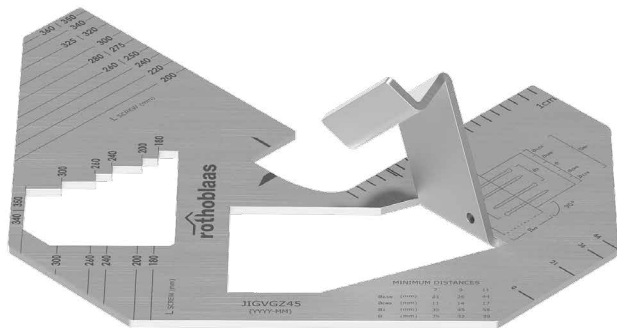

MANUALS



GEOMETRY

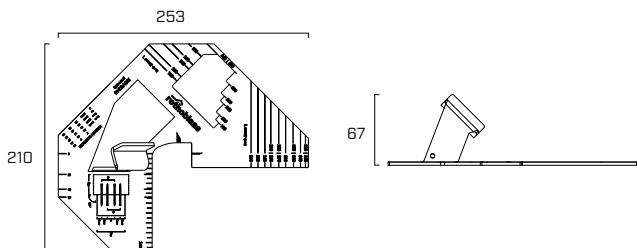

MINIMUM DISTANCES FOR CROSS SCREWS

SCREWS INSERTED WITH AND WITHOUT PRE-DRILLED HOLE

$\varnothing_{\text{screw}}$	[mm]	7	9	11
$a_{2,CG}$	[mm]	21	36	44
a_{CROSS}	[mm]	11	14	17
a_2	[mm]	35	45	55
e	[mm]	25	32	39

Recommended pilote hole for connectors $\varnothing 11 L \geq 400$ mm

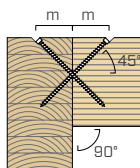

section

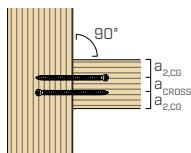

plan - 1 PAIR

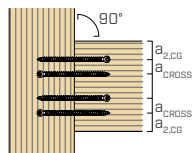

plan - 2 OR MORE PAIRS



MANUALS

VGZ



Download the installation manual

www.rothoblaas.com



■ SCREW TIP POSITIONING

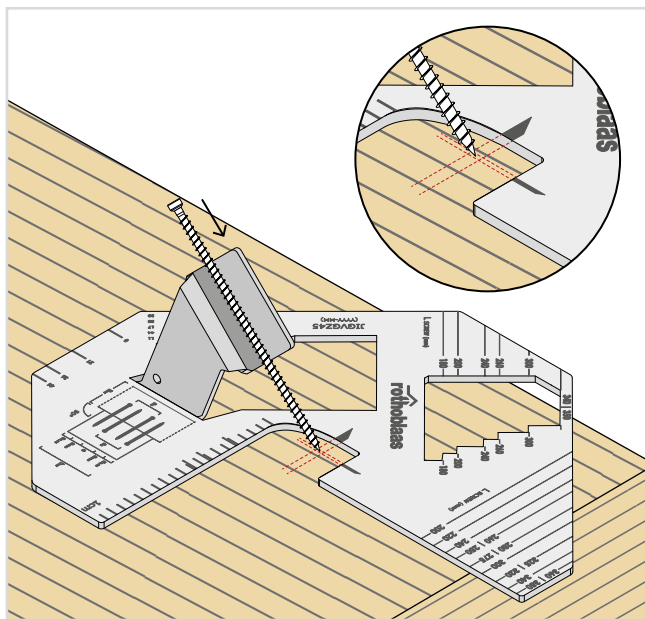
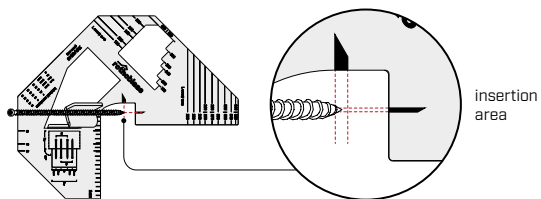

■ MAIN-SECONDARY BEAM CONNECTION

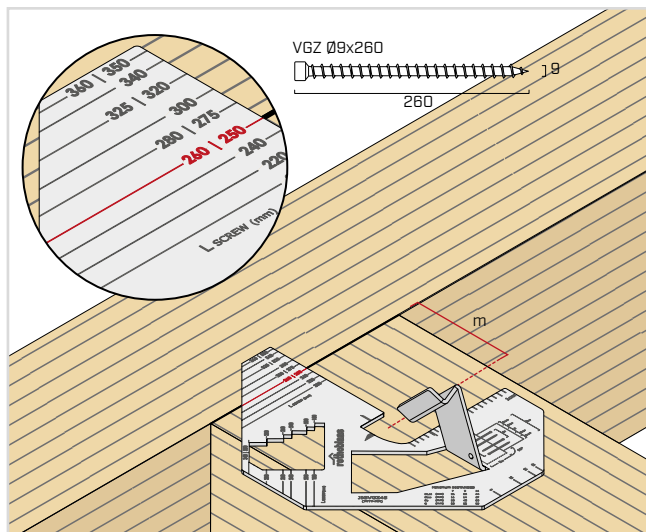
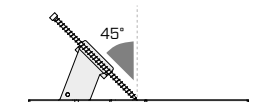
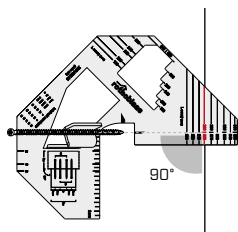
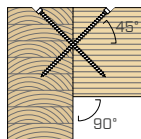

■ MINIMUM DISTANCE a_{2CG}

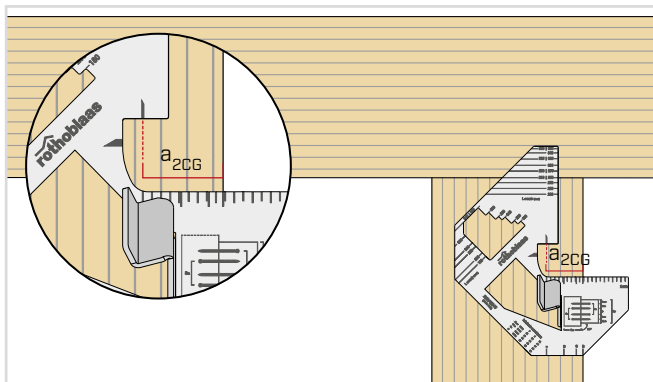

■ MINIMUM DISTANCE BETWEEN SCREWS

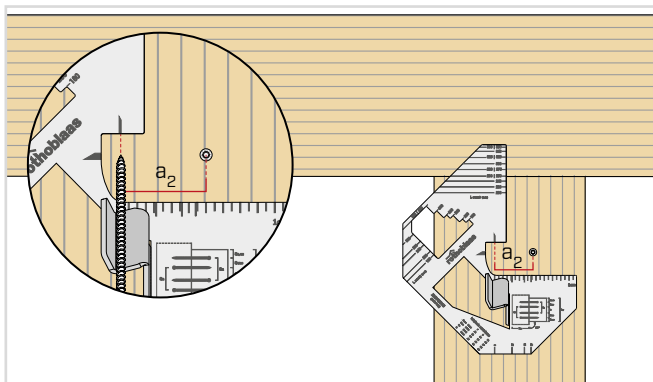

■ SIDE-BY-SIDE JOINING CLT FLOOR 45° + 45° ON THE RIGHT

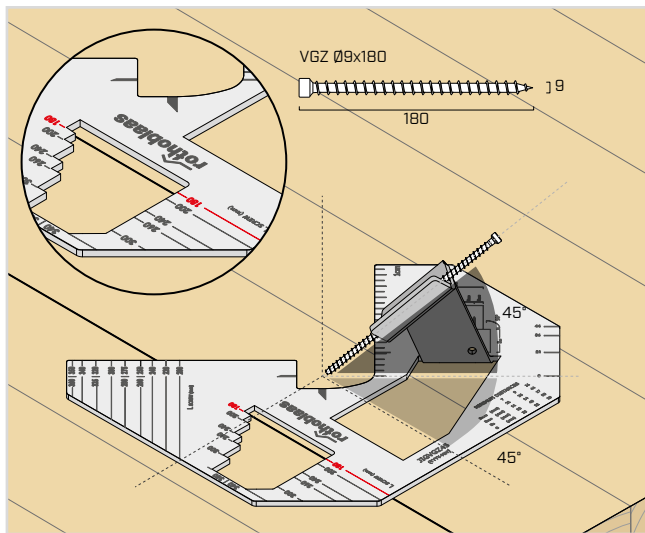
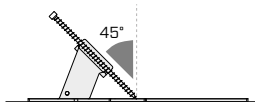
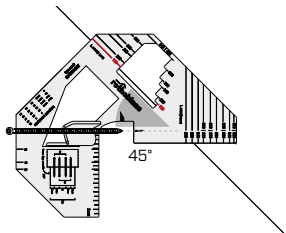
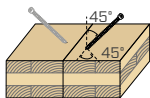

■ SIDE-BY-SIDE JOINING CLT FLOOR
45° + 45° ON THE LEFT

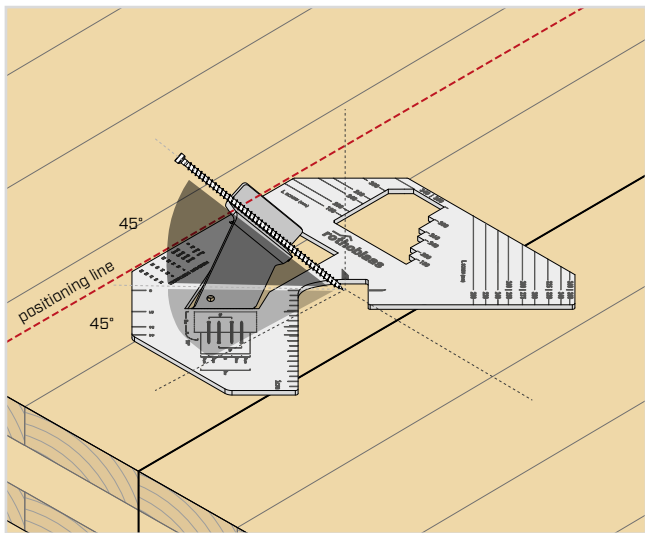
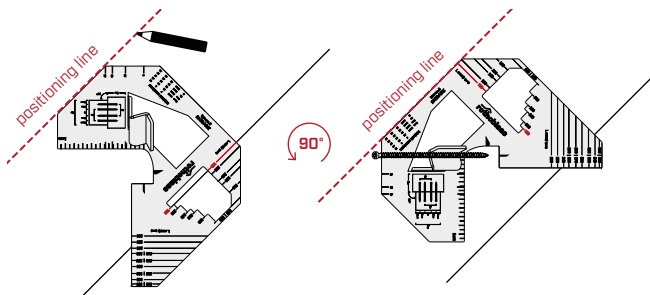
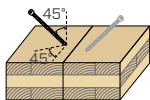

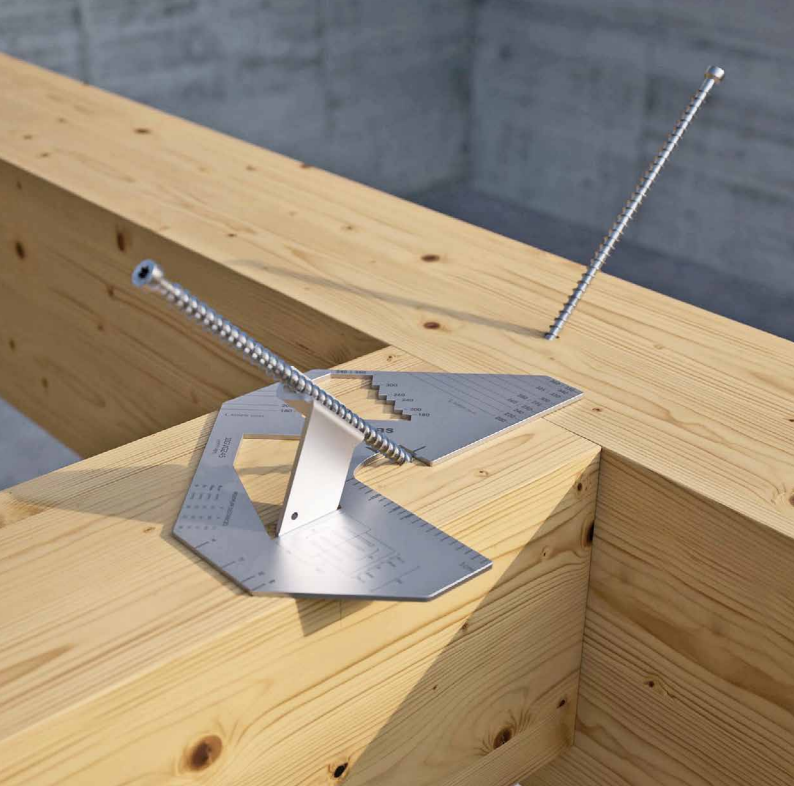

ROTHO BLAAS SRL

06|26

Via dell'Adige N.2/1 | 39040, Cortaccia (BZ) | Italia
Tel: +39 0471 81 84 00 | Fax: +39 0471 81 84 84
info@rothoblaas.com | www.rothoblaas.com

